

60CM BUILT IN FAN OVEN

INSTRUCTION
MANUAL

Creda



MODEL/S
C60BIFX
C60BIFBL

V 1.0

You'll soon be enjoying your new Creda Built In Oven!

It all begins here, with your instructions. Don't worry, there's nothing too technical coming up. Just simple, step-by-step guidance to get you up and running quickly. Sound good? Then let's get started.

Help and Guidance

We're here to help you get the most from your appliance.

Should you require any guidance, a simple solution can often be found online at:

www.creda.co.uk

If you still require further assistance, call one of our experts on **01759 487836**.

If you require any technical guidance or find that your product is not operating as intended, a simple solution can often be found in the **Troubleshooting** section of these instructions, or online at www.creda.co.uk If you still require further assistance, call one of our experts on 01759 487836.

CONTENTS

	PAGE
Important warnings	4
Electrical connection	6
Introducing the appliance	8
Accessories	9
Technical specifications	9
Installation of appliance	10
Control panel	15
Using the oven	19
Using the grill	19
Program types	20
Cooking recommendations	20
Cooking table	21
Maintenance and cleaning	21
Cleaning and mounting oven door	22
Cleaning oven glass	23
Rack positions	24
Replacing oven lamp	24
Troubleshooting	25
Handling rules	27
Recommendations for energy saving	27
Help and Assistance	28

IMPORTANT WARNINGS

1. Installation and repair should always be performed by "AUTHORIZED SERVICE". Manufacturer shall not be held responsible for operations performed by unauthorized persons.
2. Please read these operating instructions carefully. Only by this way you can use the appliance safely and in a correct manner.
3. The oven should be used according to operating instructions.
4. Keep children below the age of 8 and pets away when operating.
5. **The accessible parts may be hot during use. Young children must be kept away.**
6. **WARNING: Danger of fire: do not store items on the cooking surfaces.**
7. **WARNING: During use the appliance becomes hot. Care should be taken to avoid touching heating elements inside the oven.**
8. Setting conditions of this device are specified on the label. (Or on the data plate)
9. The accessible parts may be hot when the grill is used. Small children should be kept away.
10. **WARNING: This appliance is intended for cooking. It should not be used for other purposes like heating a room.**
11. To clean the appliance, do not use steam cleaners.
12. Ensure that the oven door is completely closed after putting food inside the oven.
13. NEVER try to put out the fire with water. Only shut down the device circuit and then cover the flame with a cover or a fire blanket.
14. **WARNING: Children less than 8 years of age shall be kept away unless continuously supervised.**
15. Touching the heating elements should be avoided.
16. **CAUTION: Cooking process shall be supervised. Cooking process shall always be supervised.**
17. This appliance can be used by children aged from 8 years and above and persons with reduced physical, sensory or mental capabilities or lack of experience and knowledge if they have been given supervision or instruction concerning use of the appliance in a safe way and understand the hazards involved. Children shall not play with the appliance. Cleaning and user maintenance shall not be made by children without supervision.
18. This device has been designed for household use only.
19. Children must not play with the appliance. Cleaning or user maintenance of the appliance shall not be performed by children unless they are older than 8 years and supervised by adults.
20. Keep the appliance and its power cord away from children less than 8 years old.
21. Put curtains, tulle, paper or any flammable (ignitable) material away from the appliance before starting to use the appliance. Do not put ignitable or flammable materials on or in the appliance.
22. Keep the ventilation channels open.
23. The appliance is not suitable for use with an external timer or a separate remote control system.
24. Do not heat closed cans and glass jars. The pressure may lead jars to explode.
25. Oven handle is not a towel drier. Do not hang towels, etc. on the oven handle.
26. Do not place the oven trays, plates or aluminum foils directly on the oven base. The accumulated heat may damage the base of the oven.

INSTRUCTION MANUAL

27. While placing food to or removing food from the oven, etc., always use heat resistant oven gloves.
28. Do not use the product in states like medicated and/or under influence of alcohol which may affect your ability of judgement.
29. Be careful when using alcohol in your foods. Alcohol will evaporate at high temperatures and may catch fire to cause a fire if it comes in contact with hot surfaces.
30. After each use, check if the unit is turned off.
31. If the appliance is faulty or has a visible damage, do not operate the appliance.
32. Do not touch the plug with wet hands. Do not pull the cord to plug off, always hold the plug.
33. Do not use the appliance with its front door glass removed or broken.
34. Place the baking paper together with the food into a pre-heated oven by putting it inside a cooker or on an oven accessory. (Tray, wire grill etc.)
35. Do not put objects that children may reach on the appliance.
36. It is important to place the wire grill and tray properly on the wire racks and/or correctly place the tray on the rack. Place the grill or tray between two rails and make sure it is balanced before putting food on it.
37. Against the risk of touching the oven heater elements, remove excess parts of the baking paper that hang over from the accessory or container.
38. Never use it at higher oven temperatures than the maximum usage temperature indicated on your baking paper. Do not place the baking paper on the base of the oven. Against the risk of touching the oven heater elements, remove excess parts of the baking paper that hang over from the accessory or container.
39. When the door is open, do not place any heavy object on the door or allow children to sit on it. You may cause the oven to overturn or the door hinges to be damaged.
40. The packaging materials are dangerous for children. Keep packaging materials away from the reach of children.
41. Do not use abrasive cleaners or sharp metal scrapers to clean the glass as the scratches that may occur on the surface of the door glass may cause the glass to break.
42. User should not handle the oven by himself.
43. During usage, the internal and external surfaces of the oven get hot. As you open the oven door, step back to avoid the hot vapour coming out from the interior. There is risk of burning.
44. Do not place heavy objects when oven door is open, risk of toppling.
45. Oven supply can be disconnected during any construction work at home. After completing the work, re-connecting the oven shall be done by authorized service.
46. User should not dislocate the resistance during cleaning. It may cause an electric shock.
47. To prevent overheating, the appliance should not be installed behind of a decorative cover.
48. Turn off the appliance before removing the safeguards. After cleaning, install the safeguards according to instructions.
49. Cable fixing point shall be protected.
50. Please don't cook the food directly on the tray / grid. Please put the food into or on appropriate tools before putting them in the oven.

ELECTRICAL SAFETY

1. Plug the appliance in a grounded socket protected by a fuse conforming to the values specified in the technical specifications chart.
2. Have an authorized electrician set grounding equipment. Our company shall not be responsible for the damages that shall be incurred due to using the product without grounding according to local regulations.
3. The circuit breaker switches of the oven shall be placed so that end user can reach them when the oven is installed.
4. The power supply cord (the cord with plug) shall not contact the hot parts of the appliance.
5. If the power supply cord (the cord with plug) is damaged, this cord shall be replaced by the manufacturer or its service agent or an equally qualified personnel to prevent a hazardous situation.
6. Never wash the appliance by spraying or pouring water on it. There is a risk of electrocution.
7. **WARNING: To avoid electric shock, ensure that the device circuit is open before changing the lamp.**
8. **WARNING: Cut off all supply circuit connections before accessing the terminals.**
9. Do not use cut or damaged cords or extension cords other than the original cord.
10. Make sure that there is no liquid or humidity in the outlet where the product plug is installed.
11. The rear surface of the oven also heats up when the oven is operated. Electrical connections shall not touch the rear surface, otherwise the connections may be damaged.
12. Do not tighten the connecting cables to the oven door and do not run them over hot surfaces. If the cord melts, this may cause the oven to short circuit and even a fire.
13. Unplug the unit during installation, maintenance, cleaning and repair.
14. If the power supply cable is damaged, it must be replaced by its manufacturer or authorized technical service or any other personnel qualified at the same level, in order to avoid any dangerous situation.
15. Make sure the plug is inserted firmly into wall socket to avoid sparks.
16. Do not use steam cleaners for cleaning the appliance, otherwise electric shock may occur.
17. An omnipolar switch capable to disconnect power supply is required for installation. Disconnection from power supply shall be provided with a switch or an integrated fuse installed on fixed power supply according to building code.
18. Appliance is equipped with a **type "Y"** cord cable.
19. Fixed connections shall be connected to a power supply enabling omnipolar disconnection. For appliances with over voltage category below III, disconnection device shall be connected to fixed power supply according to wiring code.

Intended Use

1. This product has been designed for domestic use. Commercial use is not permitted.
2. This appliance may only be used for cooking purposes. It shall not be used for other purposes like heating a room.
3. This appliance shall not be used to heat plates under the grill, drying clothes or towels by hanging them on the handle or for heating purposes.
4. The manufacturer assumes no responsibility for any damage due to misuse or mishandling.
5. Oven part of the unit may be used for thawing, roasting, frying and grilling food.
6. Operational life of the product you have purchased is 10 years. This is the period for which the spare parts required for the operation of this product as defined is provided by the manufacturer.

ELECTRICAL CONNECTION

This oven must be installed and connected to its place correctly according to manufacturer instructions and by an authorized service.

Appliance must be installed in an oven enclosure providing high ventilation.

Electrical connections of the appliance must be made only via sockets having earth system furnished in compliance with rules. Contact an authorized electrician if there is no socket complying with the earthed system at where appliance will be placed. Manufacturing company is by no means responsible for damage resulting from connection of non-earthed sockets to appliance.

Plug of your oven must be earthed; ensure that socket for the plug is earthed. Plug must be in a place that can be accessed after installation.

Your oven has been manufactured as 220-240 V 50/60 Hz. AC power supply compliant and requires a 16 Amp fuse. If your power network is different that these indicated values, refer to an electrician or your authorized service.

When you need to replace the electrical fuse, please ensure that electrical connection is made as follows:

- Phase (to live terminal) brown cable
- Blue cable to neutral terminal
- Yellow-green cable to earth terminal

Oven disconnecting switches must be in an accessible place for final user while oven is in its place.

Power supply cable (plug in cable) mustn't touch hot parts of the appliance. If supply cord (plug in cable) is damaged, this cord must be replaced by the importer or its service agent or an equally competent person to prevent a hazardous situation.

INTRODUCING THE APPLIANCE

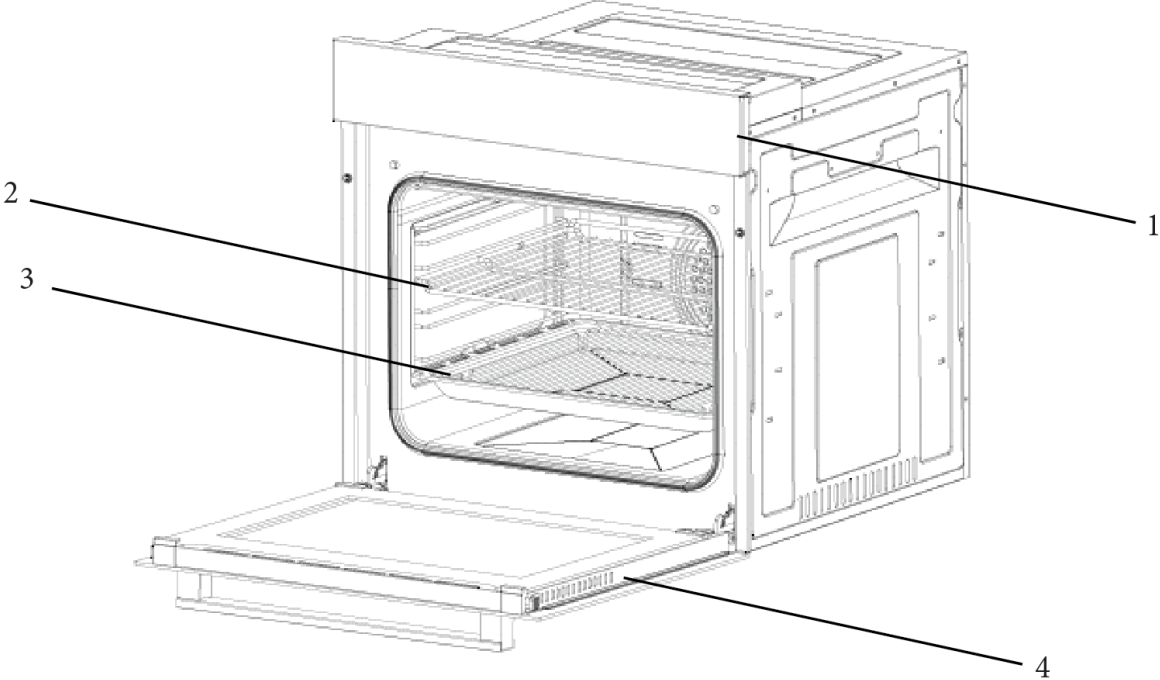

- 1. Control panel
- 2. In tray wire grill
- 3. Standard tray
- 4. Oven door
- 5. Lamp

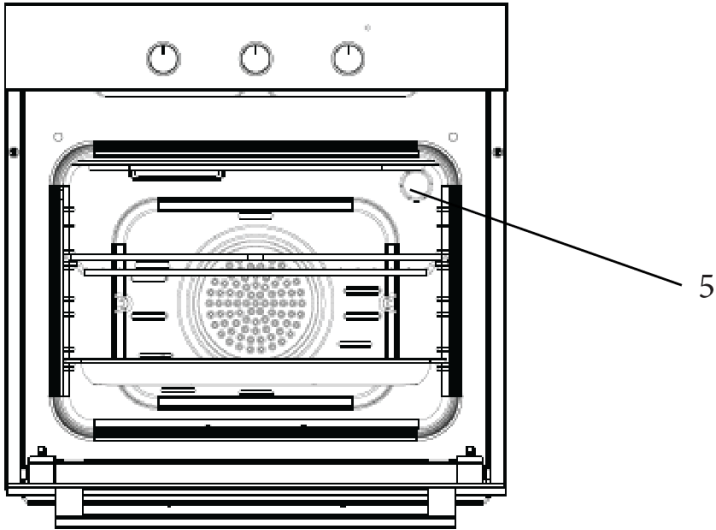

ACCESSORIES

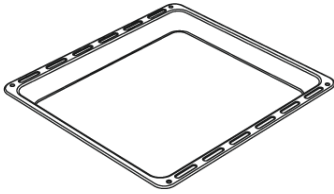

Baking tray

Used for pastry (cookie, biscuit etc.), frozen foods.

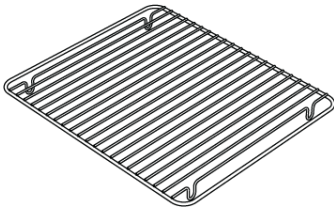

Grill tray insert

Foods to stick while cooking such as steak are placed on in tray grill. Thus, contact of food with tray and sticking are prevented.

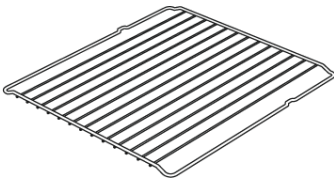

Wire grill

Used for roasting or placing foods to be baked, roasted and frozen into desired rack.

TECHNICAL SPECIFICATIONS

Specifications	C60BIFX / C60BIFBL			
Lamp power	15-25 W			
Thermostat	40-240 / Max °C			
Lower heater	1200 W			
Upper heater	1000 W			
Turbo heater	1800 W			
Grill heater	Small grill	1000 W	Big grill	2000 W
Supply voltage	220V-240 V 50/60 Hz.			

Technical specifications can be changed without prior notice to improve product quality.

The values provided with the appliance, or its accompanying documents are laboratory readings in accordance with the respective standards. These values may differ depending on the use and ambient conditions.

Figures in this guide are schematic and may not be exactly match your product.

INSTALLATION OF APPLIANCE

Ensure that electrical installation is suitable for operationalising the appliance. If not, call an electrician and plumber to make necessary arrangements. Manufacturing firm can't be hold responsible for damages to arise due to operations by unauthorized people and product warranty becomes void.

WARNING: It is customer's responsibility to prepare the location the product shall be placed on and also have power utility prepared.

WARNING: The rules about electrical local standards must be adhered to during product installation.

WARNING: Check for any damage on the product before installing it. Do not have product installed if it's damaged. Damaged products pose danger for your safety.

Important Warnings For Installation:

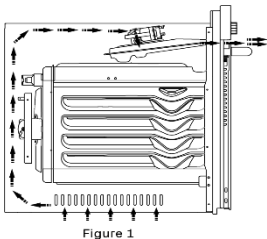

Cooling fan shall take extra steam out and prevent outer surfaces of appliance from overheating during operation of oven. This is a necessary condition for better appliance operation and better cooking. Cooling fan shall continue operation after cooking is finished. Fan shall automatically stop after cooling is completed. A clearance must be left behind the enclosure where you'll place the appliance for efficient and good operation. This clearance shouldn't be ignored as it's required for ventilation system of the appliance to operate.

Right Place For Installation

Product has been designed to be mounted to worktops procured from market. A safe distance must be left between the product and kitchen walls or furniture. See the drawing provided on the next page for proper distances. (Values in mm).

- Used surfaces, synthetic laminates and adhesives must be heat resistant. (Minimum 100 °C)
- Kitchen cupboards must be level with product and secured.
- If there is a drawer below the oven, a rack must be placed between oven and drawer.

WARNING: Do not install the product next to refrigerators or coolers. The heat emitted by the product increases the energy consumption of cooling devices.

WARNING: Do not use door and/or handle to carry or move the product.

60 Cm BUILT-IN OVEN INSTALLATION AND MOUNTING

Place of use for product must be located before starting installation.

Product mustn't be installed in places which are under the effect of strong air flow.

Carry the product with minimum two people. Do not drag the product so that floor isn't damaged.

Remove all transportation materials inside and outside the product. Remove all materials and documents in the product.

INSTRUCTION MANUAL

Installation Under Counter

Cabin must match the dimensions provided in figure 2.

A clearance must be provided at the rear part of the cabin as indicated in the figure so that necessary ventilation can be achieved.

After mounting, the clearance between lower and upper part of the counter is indicated in figure 5 with "A". It's for ventilation and shouldn't be covered.

Installation In An Elevated Cabinet

Cabin must match the dimensions provided in figure 4.

The clearances with the dimensions indicated in the figure must be provided at the rear part of cabin, upper and lower sections so that necessary ventilation can be achieved.

Installation Requirements

Product dimensions are provided in the figure 3.

Furniture surfaces for mounting and mounting materials to be used must have a minimum temperature resistance of 100 °C.

Mounting cabin must be secured and its floor must be plane for product not to tilt over.

Cabin floor must have a minimum strength that would handle a load of 60 kg.

Placing And Securing The Oven

Place the oven into the cabin with two or more people.

Ensure that oven's frame and front edge of the furniture match uniformly.

Supply cord mustn't be under the oven, squeeze in between oven and furniture or bend.

Fix the oven to the furniture by using the screws provided with the product. Screws must be mounted as shown in figure 5 by passing them through plastics attached to frame of the product. Screws mustn't be overtightened. Otherwise, screw sockets might be worn.

Check that oven doesn't move after mounting. If oven isn't mounted in accordance with instructions, there is a risk of tilt over during operation.

Electrical Connection

Mounting place of the product must have appropriate electrical installation.

Network voltage must be compatible with the values provided on type label of product.

Product connection must be made in accordance with local and national electrical requirements.

Before starting the mounting disconnect network power. Do not connect the product to network until its mounting is completed.

Mounting

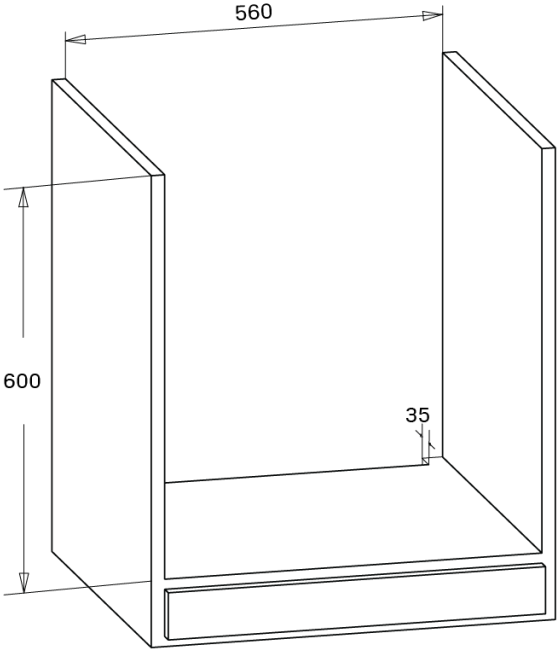
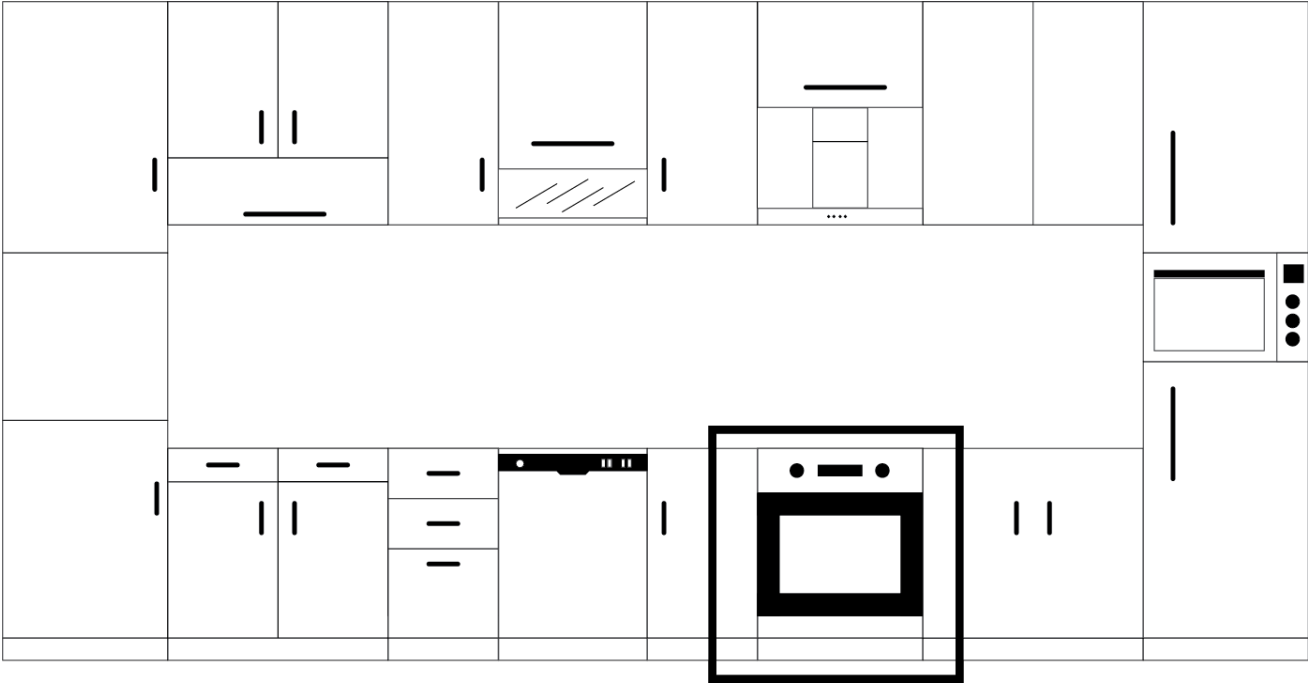
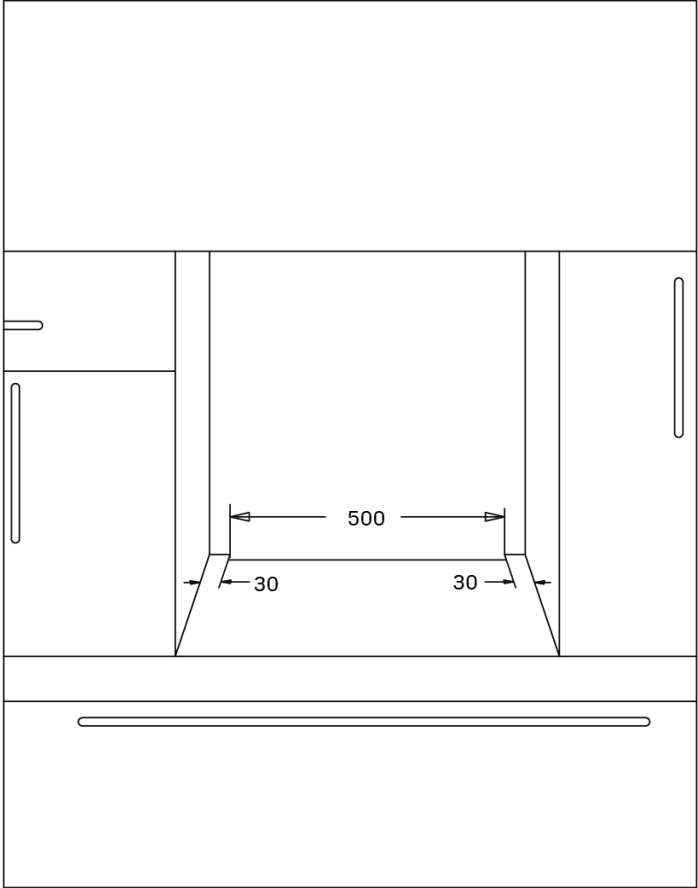

Figure 2



**INSTRUCTION
MANUAL**

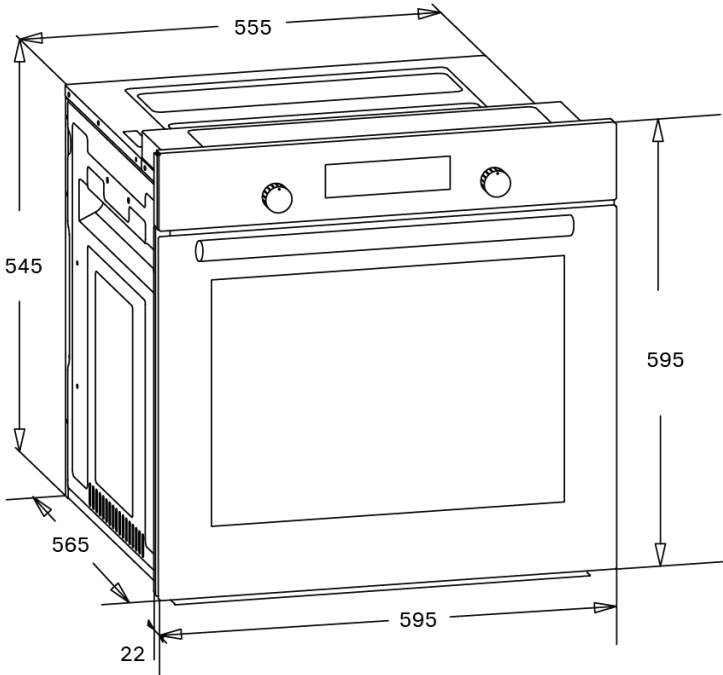
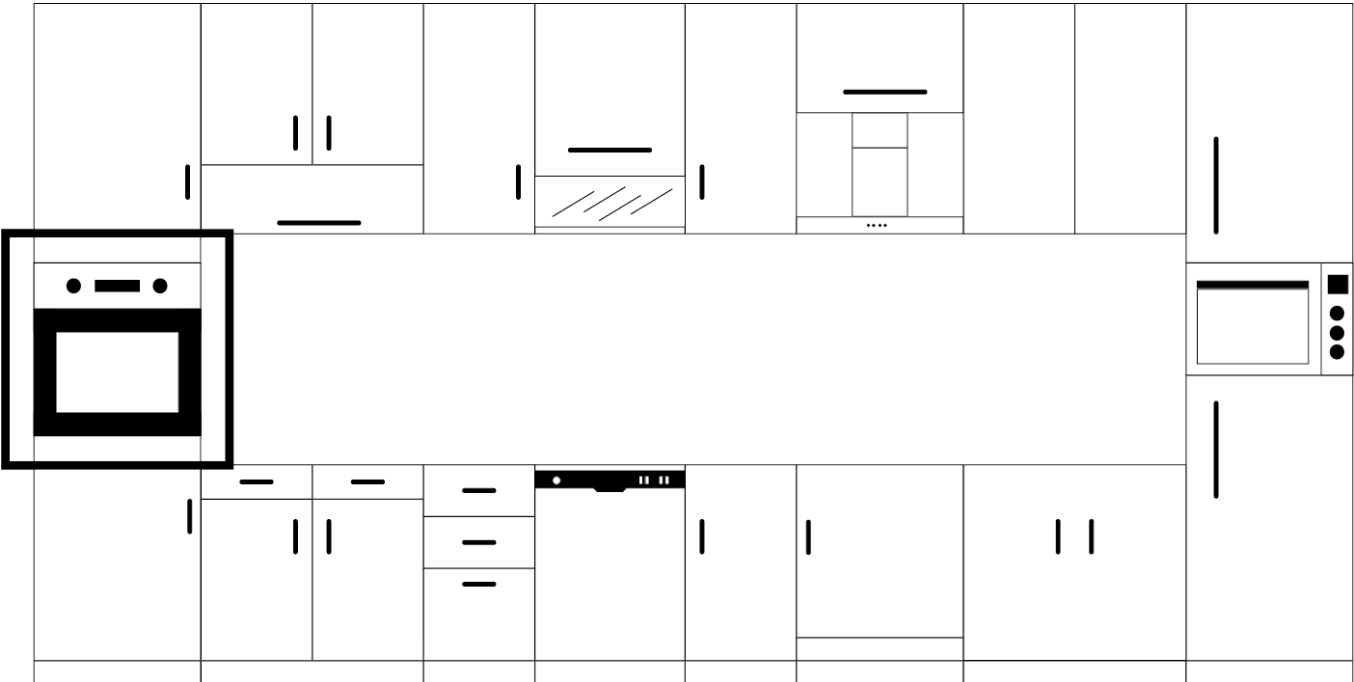

Figure 3



INSTRUCTION MANUAL

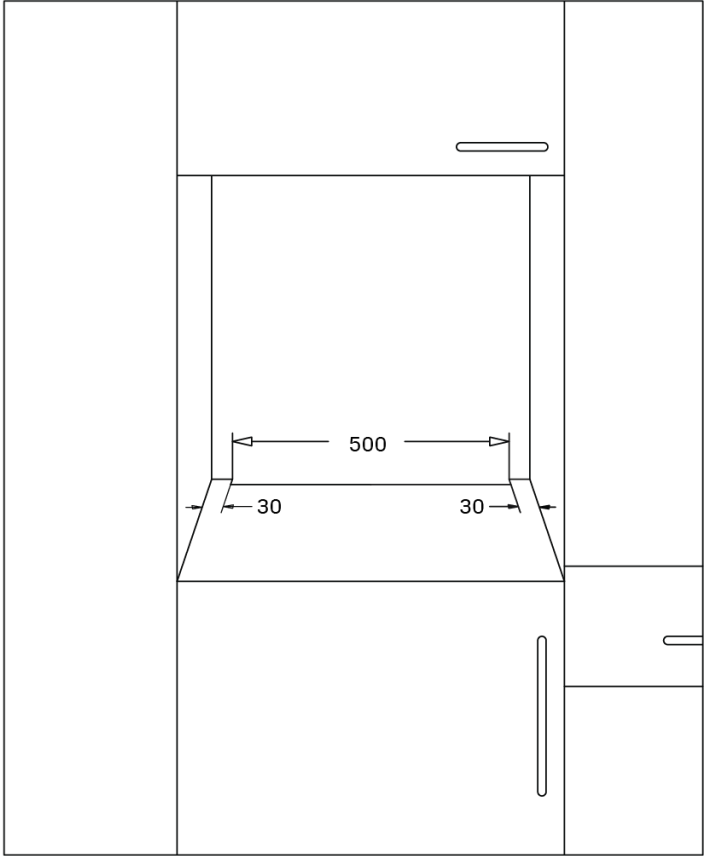
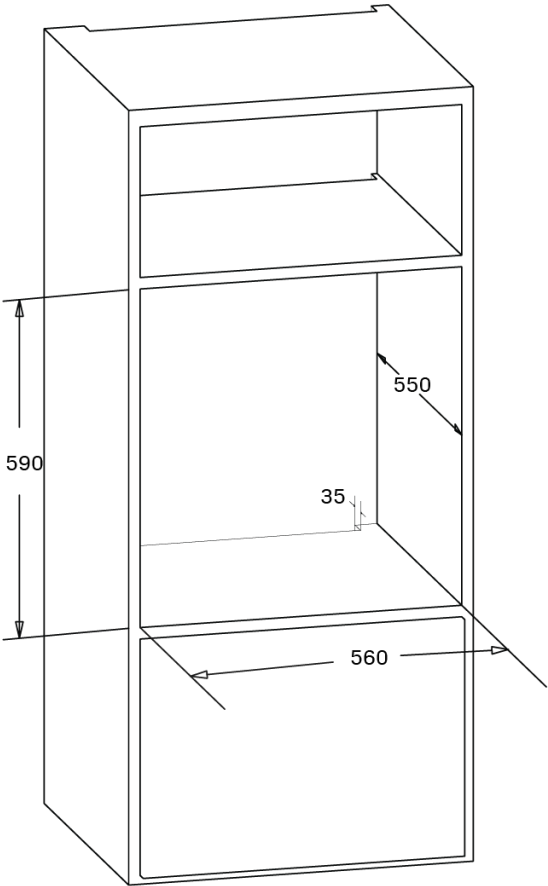

Figure 4

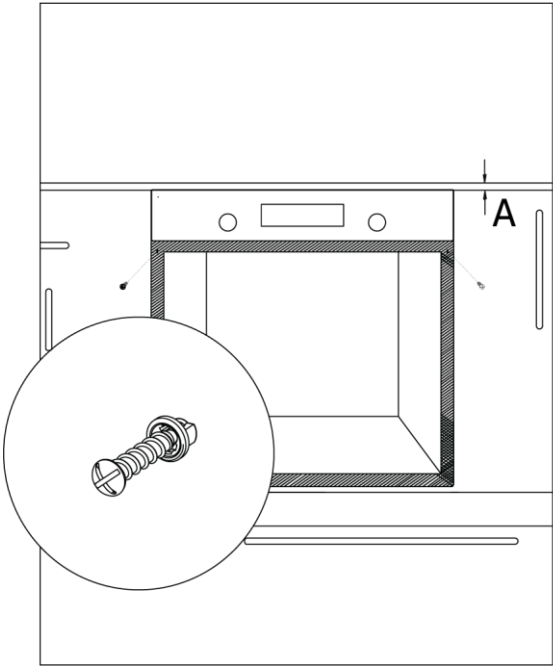
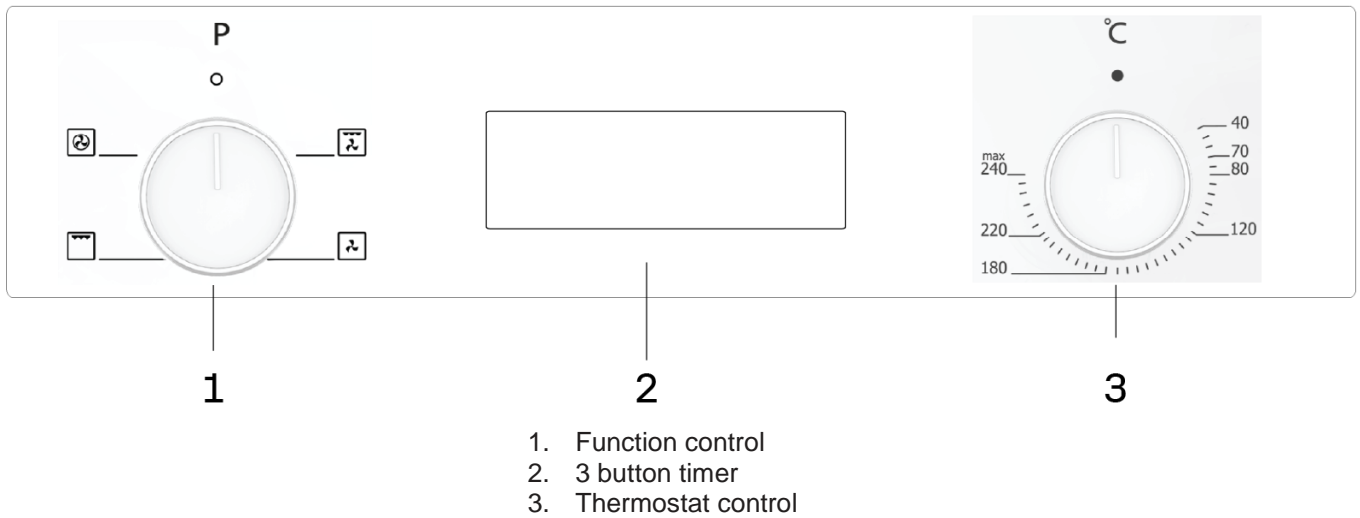
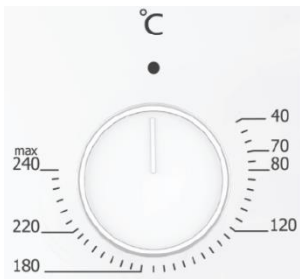

Figure 5

CONTROL PANEL



WARNING: The control panel above is only for illustration purposes. Consider the control panel on your device.









Thermostat Control: Helps to set cooking temperature of the food to be cooked in the oven. You can set the desired temperature by turning the control after placing the food into the oven. Check cooking table related to cooking temperatures of different foods.

WARNING: The control panel above is only for illustration purposes. Consider the control panel on your device.



SCREEN SYMBOLS

	<p>Oven status indication</p> <ul style="list-style-type: none"> • On: Cooking or ready for cooking. • Off: No cooking.
	<p>Minute minder status indication</p> <ul style="list-style-type: none"> • On: Minute minder alarm active. • Flashing: Minute minder adjustment mode, adjustment possible by  or  buttons or current minute minder alarm completed. • Off: Minute minder is not active.
	<p>Child lock indication</p> <ul style="list-style-type: none"> • On: Child Lock is active. • Off: Child Lock is inactive.
	<p>Automatic cooking status indication</p> <ul style="list-style-type: none"> • On: Full or semi auto-cooking active. • Flashing: Auto cooking completed or power on condition. • Off: No auto cooking active.

It is an electronic timing module enabling your food you have put in the oven to be ready for service at any time you like. The only thing you need to do is to programme the cooking time of the food and also the time when you would like your food to be ready.

It is also possible to use a minute-programmed alarm clock independent from the oven.

The case where the time clock is behind or ahead is not a malfunction. The oven time clock may be put back or ahead according to mains frequency as it runs directly with mains voltage. This is not a malfunction.

POWER ON

At power on, oven is inactive, time of day and **A** symbols are flashing. The indicated time of day is not correct and has to be adjusted. Press **⏻** to activate the oven and proceed adjusting the time of day as below.

TIME OF DAY ADJUSTMENT

Time of Day adjustment is only possible when no cooking program is in progress. Press **+** and **-** simultaneously for 3 seconds to enter the adjustment mode and then the dot symbol in between hours and minutes digits will start to flash. Using either **+** and **-** adjust the desired duration. The maximum adjustable duration is 23h 59 minutes. Adjustment mode will be abandoned within 6 seconds after the last button press or can be terminated immediately by pressing the **⏻** button.

Note: Time of day adjustment is also activated in first 7 seconds after power on.

SETTING THE MINUTE MINDER

With this function, you can adjust a duration in minutes. After the adjusted time has been elapsed, an alarm sound will be produced.

Press **⏻** button once to enter the minute minder adjustment mode, **⌚** symbol will start flashing on the screen. Using either **+** or **-**, adjust the desired duration. The maximum adjustable duration is 10 hour. Adjustment mode will be abandoned within 6 seconds after the last button press or can be terminated immediately by pressing the **⏻** button.

CANCELLING THE ALARM BUZZER SOUND

Once the adjusted minute minder duration is elapsed, the buzzer alarm will start to sound, accompanied by the flashing **⌚** symbol on the screen. Any button press will stop the alarm sound and this indication. If no button is pressed, the alarm sound will end automatically after 5 minutes, but the flashing symbol will go on.

SEMI AUTOMATIC COOKING

This cooking program is intended to start cooking immediately for a specified duration. After the oven is set to the desired function and temperature via the oven knobs:





1. Press the **⏻** button twice, **A** symbol will flash on the screen. **dur** and duration of cooking will show on the screen one after another.
2. Using **+** or **-** buttons, adjust the desired cooking duration.
3. After 6 seconds of the last button press or by pressing **⏻** twice, the adjustment is completed. **A** will be steady on the screen and the display shows the current time of day.

END OF AUTO COOKING

When the cooking is finished automatically, the **A** icon starts to flash. Alarm may be turned off by pressing any key. To disable the key lock, press the **⏻** key for 2 seconds. Oven is taken to the manual mode by pressing the **⏻** key. Audible alarm shall sound for 7 minutes if you do not press any key.

FULL AUTOMATIC COOKING

This cooking program is intended to perform a delayed cooking by programming the time of day, when the food should be ready. In other words, the oven will start cooking not immediately but will automatically calculate the time to start cooking.

1. Perform step 1 and 2 of the semi auto cooking as above **End** (cooking duration adjustment).
2. Press  button once again, **A** symbol will flash on the screen and duration of cooking will show on the screen one after another.
3. Using  or  buttons, adjust the desired end of cooking time.  symbol will disappear but **A** symbol will be still flashing on the screen. This indicates that an automatic cooking is programmed but cooking has not started yet.
4. After 6 seconds of the last button press or by pressing , the adjustment will be completed, the display shows the current time of day.



POWER INTERRUPTS

Product is not affected by short power failures (up to 50 seconds approximately), and the timer and the clock shall resume working at this period.

Your oven shall be deactivated on other failures than short term power failures (that is, more than 50 seconds) due to safety reasons. This is indicated with the flashing of the clock and the **A** on the screen. The clock shall be displayed as **12:00** and it should be set again. (See power on)





Note: The flashing **A** symbol indicates that the oven is inactive and you have to enter the manual mode.

CHILD LOCK





This function is intended to prevent any unauthorized modification of the timer settings. This function will be active, within 30 seconds after the last button press.  will appear. To deactivate it, press the  button for 3 seconds.  will disappear.

PROGRAMMABLE OPTIONS

Alarm tone:

Pressing and holding the  button for 3 seconds will result in the currently valid buzzer tone being produced. By pressing  and  buttons, you may scroll through 3 available buzzer tones. The last heard buzzer tone will be automatically recorded as the selected tone. After 6 seconds of the last button press or by pressing , the adjustment is completed.

Brightness setting:

Pressing and holding the  button for 3 seconds will result in the currently valid brightness setting being showed. By pressing  and  buttons, you may scroll through 8 available brightness setting. The last seen brightness setting will be automatically recorded as the selected setting. After 6 seconds of the last button press or by pressing , the adjustment is completed.

Note: Default settings are highest.

Note: Programmable options are nonvolatile and will be resident after any power failure.

USING THE OVEN

Initial Use Of Oven

Here are the things you must do at first use of your oven after making its necessary connections as per instructions:

1. Remove labels or accessories attached inside the oven. If any, take out the protective folio on front side of the appliance.
2. Remove dust and package residues by wiping inside of the oven with a damp cloth. Inside of oven must be empty. Plug the cable of appliance into the electrical socket.
3. Set the thermostat control to the highest temperature (240 Max. °C) and run the oven for 30 minutes with its door closed. Meanwhile a slight smoke and smell might occur and that's a normal situation.
4. Wipe inside of the oven with a slightly warm water with detergent after it becomes cold and then dry with a clean cloth. Now you can use your oven.

Normal Use Of Oven

1. Adjust thermostat control and temperature at which you want to cook the food to start cooking.
2. You can set cooking time to any desired time by using the 3 button timer. Timer will de-energise heaters when time expired and provide warning beep as ringing.
3. Timer turns the heaters off and provides audible signal when cooking time expires in line with the information entered in the models with digital timer.
4. Cooling system of the appliance will continue to operate after cooking is completed. Do not cut the power of appliance in this situation which is required for appliance to cool down. System will shut down after cooling is completed.

USING THE GRILL

1. When you place the grill on the top rack, the food on the grill shall not touch the grill.
2. You can preheat for 5 minutes while grilling. If necessary, you may turn the food upside down.
3. Food shall be in the center of the grill to provide maximum air flow through the oven.

To turn on the grill;

1. Place the function button over the grill symbol.
2. Then, set it to the desired grill temperature.

To turn the grill off;

Set the function button to the off position.



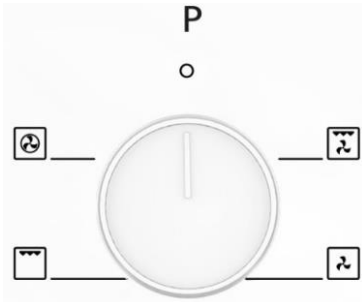

WARNING: Keep the oven door closed while grilling.

PROGRAM TYPES

Program Control: The program types help you select the best program for the best cooking results. Tables and information listed below for your reference and guidance.



Cooking Program types:

	Turbo heater and fan
	Fan
	Grill
	Grill and fan

Grill: Grill cooker is used for grilling meat like foods such as steak, sausage and fish. While grilling, tray should be placed in the lower rack and water must be placed in it.

Turbo heater and fan: Suitable for baking and roasting. Keep heat setting lower than "Lower and Upper Heater" program since heat is conveyed immediately via air flow.

Grill and fan: Suitable for cooking meat type foods. Do not forget to place a cooking tray in a lower rack inside the oven and a little water in it while grilling.

COOKING RECOMMENDATIONS

You can find in the following table the information of food types which we tested and identified their cooking values in our labs. Cooking times can vary depending on the network voltage, quality of material to be cooked, quantity and temperature. Dishes to cook by using these values might not appeal to your taste. You can set various values for obtaining different tastes and results appealing to your taste by making tests.

WARNING: Oven must be preheated for 7-10 minutes before placing the food in it.

COOKING TABLE

MFA1-6..... :

Food	Cooking function	Cooking temperature (°C)	Cooking rack	Cooking time (min.)
Cake	Static / Static+fan	170-180	2-3	35-45
Pie	Static / Static+fan	180-200	2	35-45
Pastry	Static	180-190	2	20-25
Cookie	Static	170-180	2	20-25
Apple pie	Static / Turbo+fan	180-190	1	50-70
Sponge cake	Static	200/150 *	2	20-25
Pizza	Static fan	180-200	3	20-30
Lasagne	Static	180-200	2-3	25-40
Meringue	Static	100	2	50
Grilled chicken **	Grill+fan	200-220	3	25-35
Grilled fish **	Grill+fan	200-220	3	25-35
Steak **	Grill+fan	Max	4	15-20
Grilled meatball **	Grill+fan	Max	4	20-25

MAINTENANCE AND CLEANING

1. Remove the power plug from electrical socket.
2. Do not clean inner parts, panel, trays and other parts of the product with hard tools such as bristle brush, wire wool or knife. Do not use abrasive, scratching materials or detergent.
3. Rinse after wiping the parts at inner parts of the product with soapy cloth, then dry thoroughly with a soft cloth.
4. Clean glass surfaces with special glass cleaning material.
5. Do not clean your product with steam cleaners.
6. Never use combustibles like acid, thinner and gas while cleaning your product.
7. Do not wash any part of the product in dishwasher.
8. Use potassium separate (soft soap) for dirt and stains.

CLEANING AND MOUNTING OVEN DOOR

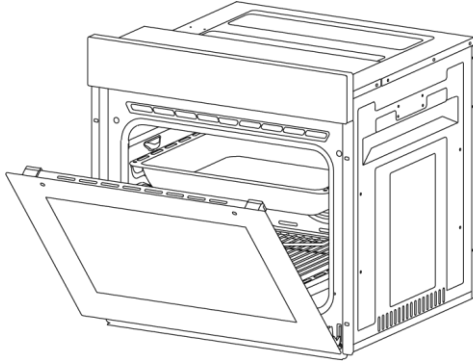

Figure 8

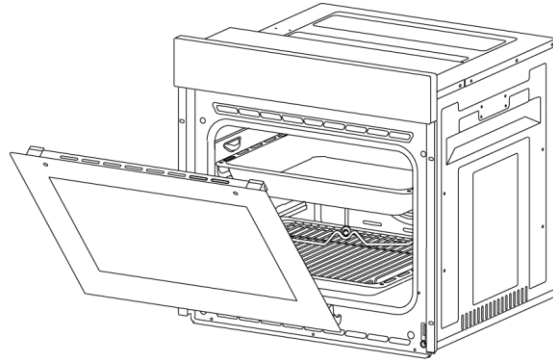

Figure 9

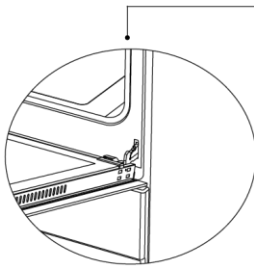

Figure 8.1

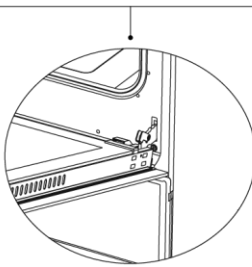

Figure 8.2

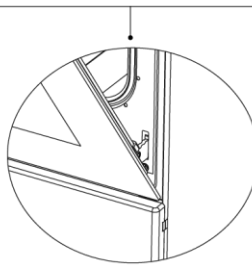

Figure 9.1

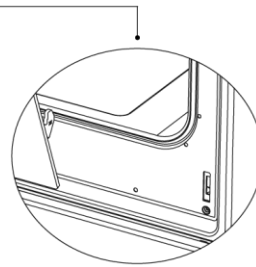

Figure 9.2

Open the door fully by pulling the oven door toward yourself. Then perform unlock operation by pulling the hinge lock upwards with the aid of screwdriver as indicated in **figure 8.1**.

Set the hinge lock to the widest angle as in **figure 8.2**. Adjust both hinges connecting oven door to the oven to the same position.

Later, close the opened oven door so that it will be in a position to contact with hinge lock as in **figure 9.1**.

For easier removal of oven door, when it comes close to closed position, hold the cover with two hands as in **figure 9.2** and pull upwards.

NOTE: Reversely perform respectively what you did while opening door to reinstall oven door back.

CLEANING OF THE OVEN GLASS

Your product may differ. Follow the appropriate step for your product.

1. Press the plastic latches on the left and right sides as shown in Figure 10 and lift the the profile by pulling it towards you as shown in Figure 11. Glass will be free after the profile is removed as shown in Figure 12. Carefully pull the glass that has become free toward you. If necessary, the middle glass can also be removed in the same way. The outer glass is fixed to the oven door profile. You may easily clean the glasses after they have been separated. Once the cleaning and maintenance is complete, you can replace the glasses and the profile by performing the removal procedure in reverse. Make sure that the glass is inserted in the correct direction and that the profile is seated properly.

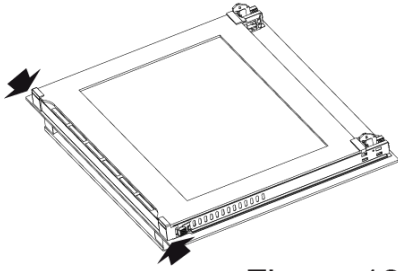

Figure 10

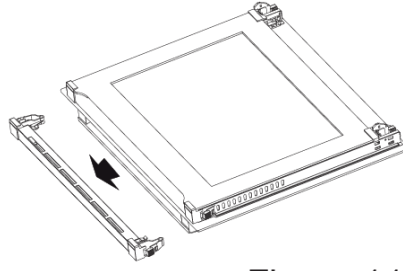

Figure 11

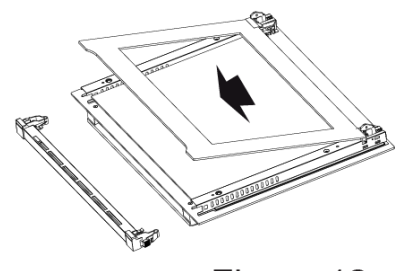

Figure 12

2. Remove the profile by pulling it towards you as shown in Figure 14. Glass will be free after the profile is removed as shown in Figure 15. Carefully pull the glass that has become free toward you. If necessary, the middle glass can also be removed in the same way. The outer glass is fixed to the oven door profile. You may easily clean the glass once it has been released. Once the cleaning and maintenance is complete, you can replace the glasses and the profile by performing the removal procedure in reverse. Make sure that the glass is inserted in the correct direction and that the profile is seated properly.

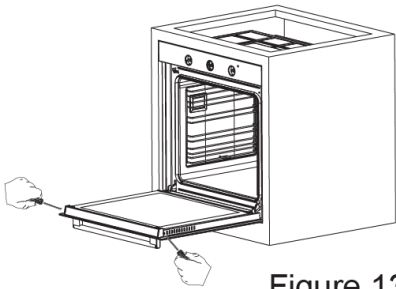

Figure 13

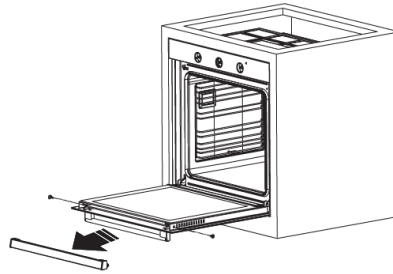

Figure 14

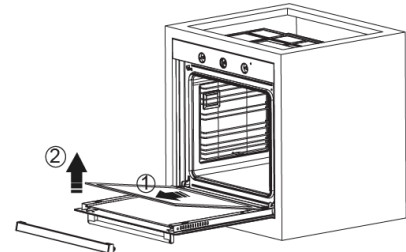
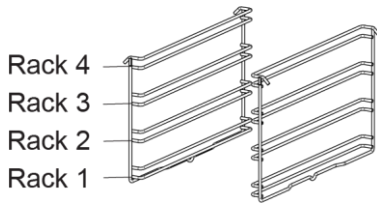

Figure 15

RACK POSITIONS



It is important to place the wire grill into the oven properly. Do not allow wire rack to touch rear wall of the oven. Rack positions are shown in the next figure. You may place a deep tray or a standard tray in the lower and upper wire racks.

Installing and removing wire racks

To remove wire racks, press the clips shown with arrows in the figure, first remove the lower, and then the upper side from installation location. To install wire racks; reverse the procedure for removing wire rack.

REPLACING OVEN LAMP

WARNING: To avoid electric shock, ensure that the appliance circuit is open before changing the lamp. (Having circuit open means power is off) First disconnect the power of appliance and ensure that appliance is cold.

Remove the glass protection by turning as indicated in the figure on the left side. If you have difficulty in turning, then using plastic gloves will help you in turning.

Then remove the lamp by turning, install the new lamp with same specifications.

Reinstall glass protection, plug the power cable of appliance into electrical socket and complete replacement. Now you can use your oven.

Type G9 Lamp



220-240 V, AC
15 W

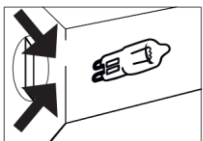

Figure 16

TROUBLESHOOTING

You may solve the problems you may encounter with your product by checking the following points before calling the technical service.

Check Points

In case you experience a problem about the oven, first check the table below and try out the suggestions.

Problem	Possible Cause	What to Do
Oven does not operate.	Power supply not available.	Check for power supply.
Oven stops during cooking.	Plug comes out from the wall socket.	Re-install the plug into wall socket.
Turns off during cooking.	Too long continuous operation.	Let the oven cool down after long cooking cycles.
	Cooling fan not operating.	Listen the sound from the cooling fan.
	Oven not installed in a location with good ventilation.	Make sure clearances specified in operating instructions are maintained.
	More than one plugs in a wall socket.	Use only one plug for each wall socket.
Outer surface of the oven gets very hot during operation.	Oven not installed in a location with good ventilation.	Make sure clearances specified in operating instructions are maintained.
Oven door is not opening properly.	Food residues jammed between the door and internal cavity.	Clean the oven well and try to re-open the door.
Internal light is dim or does not operate.	Foreign object covering the lamp during cooking.	Clean internal surface of the oven and check again.
	Lamp might be failed.	Replace with a lamp with same specifications.
Electric shock when touching the oven.	No proper grounding.	Make sure power supply is grounded properly.
	Ungrounded wall socket is used.	

INSTRUCTION MANUAL

Problem	Possible Cause	What to Do
Water dripping.	Water or steam may generate under certain conditions depending on the food being cooked. This is not a fault of the appliance.	Let the oven cool down and then wipe dry with a cloth.
Steam coming out from a crack on oven door.		
Water remaining inside the oven.		
The cooling fan continues to operate after cooking is finished.	The fan operates for a certain period for ventilation of internal cavity of the oven.	This is not a fault of the appliance; therefore, you don't have to worry.
Oven does not heat.	Oven door is open.	Close the door and restart.
	Oven controls not correctly adjusted.	Read the section regarding operation of the oven and reset the oven.
	Fuse tripped or circuit breaker turned off.	Replace the fuse or reset the circuit breaker. If this is repeating frequently, call an electrician.
Smoke coming out during operation.	When operating the oven for the first time	Smoke comes out from the heaters. This is not a fault. After 2-3 cycles, there will be no more smoke.
	Food on heater.	Let the oven to cool down and clean food residues from the ground of the oven and surface of upper heater.
When operating the oven burnt or plastic odour coming out.	Plastic or other not heat resistant accessories are being used inside the oven.	At high temperatures, use suitable glassware accessories.
Oven does not cook well.	Oven door is opened frequently during cooking.	Do not open oven door frequently, if the food you are cooking does not require turning. If you open the door frequently internal temperature drops and therefore cooking result will be influenced.

HANDLING RULES

1. Do not use the door and/or handle to carry or move the appliance.
2. Carry out the movement and transportation in the original packaging.
3. Pay maximum attention to the appliance while loading/unloading and handling.
4. Make sure that the packaging is securely closed during handling and transportation.
5. Protect from external factors (such as humidity, water, etc.) that may damage the packaging.
6. Be careful not to damage the appliance due to bumps, crashes, drops, etc. while handling and transporting and not to break or deform it during operation.

RECOMMENDATIONS FOR ENERGY SAVING

Following details will help you use your product ecologically and economically.

1. Use dark coloured and enamel containers that conduct the heat better in the oven.
2. As you cook your food, if the recipe or the user manual indicates that pre-heating is required, pre-heat the oven.
3. Do not open the oven door frequently while cooking.
4. Try not to cook multiple dishes simultaneously in the oven. You may cook at the same time by placing two cookers on the wire rack.
5. Cook multiple dishes successively. The oven will not lose heat.
6. Turn off the oven a few minutes before the expiration time of cooking. In this case, do not open the oven door.
7. Defrost the frozen food before cooking.

Help and assistance

If you require any technical guidance or find that your Built In Oven is not operating as intended, a simple solution can often be found in the Troubleshooting section of these instructions or online at www.creda.co.uk

If you still require further assistance, call one of our experts on **01759 487836**. To help give us give you a fast and efficient service please have the following information ready:

You can find the following on the rating plate - a small information panel (usually a sticker or metal plate) on the rear of your appliance.

Model Ref.	<input type="text"/>
Serial number	<input type="text"/>
Date of purchase	<input type="text"/>

Local call rates apply*

Lines open 9am-5:30pm Monday to Friday

*Calls to Creda enquiry lines may attract a charge and set up fee from residential lines depending on your call plan/tariff. Mobile and other providers costs may vary, see www.bt.com/pricing for details.

For Security and training purposes, telephone calls to and from customer service centres maybe recorded and monitored. Calls from Republic of Ireland will attract international call charges.

Creda

Call us now and activate your 3 years guarantee

Thank you for choosing Creda. Your new product is guaranteed against faults and breakdowns for 3 years. Don't forget to register it with us today so we can provide you with our best possible after-sales service and useful updates.

www.creda.co.uk

01759 487836

Your Creda Guarantee

This product is guaranteed for 3 years from the date of original purchase. Any defect that arises due to faulty materials or workmanship will be repaired free of charge (or if applicable the product will be replaced or the purchase price refunded) where possible during this period by the dealer from who you purchased the unit.

The guarantee is subject to the following provisions:

- The guarantee does not cover accidental damage, misuse, cabinet parts, knobs or consumable items.
- The product must be correctly installed and operated in accordance with the instructions contained in the manual.
- It must be used solely for domestic purposes. The guarantee will be rendered invalid if the product is re-sold or has been damaged by inexpert repair.
- Specifications are subject to change without notice.
- Creda disclaim any liability for loss or damage arising from the breakdown of the product.
- This guarantee is in addition to and does not diminish your statutory or legal rights.

Important Data Protection Information

To find out how we use your data please refer to the guarantee registration material or visit www.creda.co.uk

INSTRUCTION MANUAL

Declaration of conformance to product standards

This appliance conforms to all relevant standards applicable to domestic appliances sold in the UK.

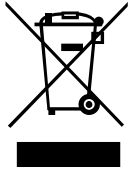

Disposal

This appliance/fitting is marked according to the European directive 2012/19/EU on Waste Electrical and Electronic Equipment (WEEE).

By ensuring this product is disposed of correctly, you will help prevent potential negative consequences for the environment and human health, which could otherwise be caused by inappropriate waste handling of this product.

The symbol on the product, or on the documents accompanying the product, the **crossed out wheeled bin** symbol, indicates that this appliance/fitting may not be treated as household waste. Instead, it shall be handed over to the applicable collection point for the recycling of electrical and electronic equipment.

Disposal must be carried out in accordance with local environmental regulations for waste disposal.

For more detailed information about treatment, recovery and recycling of this product, please contact your local authority, your household waste disposal service or the retailer where you purchased the product.

INSTRUCTION MANUAL

This page is intentionally blank

Creda