

**60CM MULTI FUNCTION BUILT IN
OVEN, WITH TOUCH TIMER**

**USER
MANUAL**

Creda



V 1.0

MODEL/S
C80BISMFTCBX
C80BISMFTCX
C80BISMFTCBL

You'll soon be enjoying your new Creda Built In Oven!

It all begins here, with your instructions. Don't worry, there's nothing too technical coming up. Just simple, step-by-step guidance to get you up and running quickly. Sound good? Then let's get started.

Help and Guidance

We're here to help you get the most from your Built In Oven.
Should you require any guidance, a simple solution can often be found online at:

www.creda.co.uk

If you still require further assistance, call one of our experts on **0175 9487836**.

If you require any technical guidance or find that your product is not operating as intended, a simple solution can often be found in the **Troubleshooting** section of these instructions, or online at www.creda.co.uk If you still require further assistance, call one of our experts on **0175 9487836**.

Contents

—	PAGE
Important warnings	4
Electrical connection	6
Introducing the appliance	7
Accessories	8
Technical specifications	9
Installation of the appliance	9
Operation of the oven	14
Operation of the grill	35
Cooking recommendations	35
Cooking table	36
Maintenance and cleaning	37
Cleaning and assembly of the oven door	38
Wire rack positions	39
Replacement of the oven lamp	39
Troubleshooting	40
Handling rules	41
Recommendations for energy saving	42
Environmentally-friendly disposal	42
	3

IMPORTANT WARNINGS

1. Installation and repair should always be performed by “**AUTHORIZED SERVICE**”. Manufacturer shall not be held responsible for operations performed by unauthorized persons.
2. Please read these operating instructions carefully. Only by this way you can use the appliance safely and in a correct manner.
3. The oven should be used according to operating instructions.
4. Keep children below the age of 8 and pets away when operating.
5. **The accessible parts may be hot during use. Young children must be kept away.**
6. **WARNING: Danger of fire: do not store items on the cooking surfaces.**
7. **WARNING: During use the appliance becomes hot. Care should be taken to avoid touching heating elements inside the oven.**
8. Setting conditions of this device are specified on the label. (Or on the data plate)
9. The accessible parts may be hot when the grill is used. Small children should be kept away.
10. **WARNING: This appliance is intended for cooking. It should not be used for other purposes like heating a room.**
11. To clean the appliance, do not use steam cleaners.
12. Ensure that the oven door is completely closed after putting food inside the oven.
13. NEVER try to put out the fire with water. Only shut down the device circuit and then cover the flame with a cover or a fire blanket.
14. **WARNING: Children less than 8 years of age shall be kept away unless continuously supervised.**
15. Touching the heating elements should be avoided.
16. **CAUTION: Cooking process shall be supervised. Cooking process shall always be supervised.**
17. This appliance can be used by children aged from 8 years and above and persons with reduced physical, sensory or mental capabilities or lack of experience and knowledge if they have been given supervision or instruction concerning use of the appliance in a safe way and understand the hazards involved. Children shall not play with the appliance. Cleaning and user maintenance shall not be made by children without supervision.
18. This device has been designed for household use only.
19. Children must not play with the appliance. Cleaning or user maintenance of the appliance shall not be performed by children unless they are older than 8 years and supervised by adults.
20. Keep the appliance and its power cord away from children less than 8 years old.
21. Put curtains, tulle, paper or any flammable (ignitable) material away from the appliance before starting to use the appliance. Do not put ignitable or flammable materials on or in the appliance.
22. Keep the ventilation channels open.
23. The appliance is not suitable for use with an external timer or a separate remote control system.
24. Do not heat closed cans and glass jars. The pressure may lead jars to explode.
25. Oven handle is not a towel drier. Do not hang towels, etc. on the oven handle.
26. Do not place the oven trays, plates or aluminium foils directly on the oven base. The accumulated heat may damage the base of the oven.
27. While placing food to or removing food from the oven, etc., always use heat resistant oven gloves.
28. Do not use the product in states like medicated and/or under influence of alcohol which may affect your ability of judgement.
29. Be careful when using alcohol in your foods. Alcohol will evaporate at high temperatures and may catch fire to cause a fire if it comes in contact with hot surfaces.
30. After each use, check if the unit is turned off.
31. If the appliance is faulty or has a visible damage, do not operate the appliance.
32. Do not touch the plug with wet hands. Do not pull the cord to plug off, always hold the plug.
33. Do not use the appliance with its front door glass removed or broken.
34. Place the baking paper together with the food into a pre-heated oven by putting it inside a cooker or on an oven accessory. (Tray, wire grill etc.)
35. Do not put objects that children may reach on the appliance.
36. It is important to place the wire grill and tray properly on the wire racks and/or correctly place the tray on the rack. Place the grill or tray between two rails and make sure it is balanced before putting food on it.
37. Against the risk of touching the oven heater elements, remove excess parts of the baking paper that hang over from the accessory or container.
38. Never use it at higher oven temperatures than the maximum usage temperature indicated on your baking paper. Do not place the baking paper on the base of the oven. Against the risk of touching the oven heater elements, remove excess parts of the baking paper that hang over from the accessory or container.

USER MANUAL

39. When the door is open, do not place any heavy object on the door or allow children to sit on it. You may cause the oven to overturn or the door hinges to be damaged.
40. The packaging materials are dangerous for children. Keep packaging materials away from the reach of children.
41. Do not use abrasive cleaners or sharp metal scrapers to clean the glass as the scratches that may occur on the surface of the door glass may cause the glass to break.
42. User should not handle the oven by himself.
43. During usage, the internal and external surfaces of the oven get hot. As you open the oven door, step back to avoid the hot vapour coming out from the interior. There is risk of burning.
44. Do not place heavy objects when oven door is open, risk of toppling.
45. Oven supply can be disconnected during any construction work at home. After completing the work, re-connecting the oven shall be done by authorized service.
46. User should not dislocate the resistance during cleaning. It may cause an electric shock.
47. To prevent overheating, the appliance should not be installed behind of a decorative cover.
48. Turn off the appliance before removing the safeguards. After cleaning, install the safeguards according to instructions.
49. Cable fixing point shall be protected.
50. Please don't cook the food directly on the tray / grid. Please put the food into or on appropriate tools before putting them in the oven.

Electrical Safety

1. Plug the appliance in a grounded socket protected by a fuse conforming to the values specified in the technical specifications chart.
2. Have an authorized electrician set grounding equipment. Our company shall not be responsible for the damages that shall be incurred due to using the product without grounding according to local regulations.
3. The circuit breaker switches of the oven shall be placed so that end user can reach them when the oven is installed.
4. The power supply cord (the cord with plug) shall not contact the hot parts of the appliance.
5. If the power supply cord (the cord with plug) is damaged, this cord shall be replaced by the manufacturer or its service agent or an equally qualified person to prevent a hazardous situation.
6. Never wash the appliance by spraying or pouring water on it. There is a risk of electrocution.
7. **WARNING: To avoid electric shock, ensure that the device circuit is open before changing the lamp.**
8. **WARNING: Cut off all supply circuit connections before accessing the terminals.**
9. Do not use cut or damaged cords or extension cords other than the original cord.
10. Make sure that there is no liquid or humidity in the outlet where the product plug is installed.
11. The rear surface of the oven also heats up when the oven is operated. Electrical connections shall not touch the rear surface, otherwise the connections may be damaged.
12. Do not tighten the connecting cables to the oven door and do not run them over hot surfaces. If the cord melts, this may cause the oven to short circuit and even a fire.
13. Unplug the unit during installation, maintenance, cleaning and repair.
14. If the power supply cable is damaged, it must be replaced by its manufacturer or authorized technical service or any other personnel qualified at the same level, in order to avoid any dangerous situation.
15. Make sure the plug is inserted firmly into wall socket to avoid sparks.
16. Do not use steam cleaners for cleaning the appliance, otherwise electric shock may occur.
17. An omnipolar switch capable to disconnect power supply is required for installation. Disconnection from power supply shall be provided with a switch or an integrated fuse installed on fixed power supply according to building code.
18. Appliance is equipped with a **type "Y"** cord cable.
19. Fixed connections shall be connected to a power supply enabling omnipolar disconnection. For appliances with over voltage category below III, disconnection device shall be connected to fixed power supply according to wiring code.

Intended Use

1. This product has been designed for domestic use. Commercial use is not permitted.
2. This appliance may only be used for cooking purposes. It shall not be used for other purposes like heating a room.
3. This appliance shall not be used to heat plates under the grill, drying clothes or towels by hanging them on the handle or for heating purposes.
4. The manufacturer assumes no responsibility for any damage due to misuse or mishandling.
5. Oven part of the unit may be used for thawing, roasting, frying and grilling food.
6. Operational life of the product you have purchased is 10 years. This is the period for which the spare parts required for the operation of this product as defined is provided by the manufacturer.

ELECTRICAL CONNECTION

This oven shall be correctly installed and connected by the authorized service and according to the manufacturer's instructions.

The appliance shall be installed in an oven housing which provides high ventilation.

The electrical connections of the appliance shall be made only by using grounded sockets equipped with a grounding system laid in accordance with the instructions. If the place where the appliance shall be installed is not designed for a grounded system, immediately contact an authorized service. The manufacturer shall never be responsible for damages caused by non-grounded sockets, to which the appliance has been plugged.

Your oven's plug is grounded; make sure that the outlet you shall connect the plug is grounded, too. The plug shall be placed so that it can be accessed after installation.

Your oven is manufactured as compatible with the 220-240 V 50/60 Hz. AC power supply and requires a fuse of 16 Amp. If your power network does not provide these specifications, contact an electrician or an authorized service.

When you need to replace the fuse, please make sure that the electrical connection is as follows:

- Brown wire to the phase (live end)
- Blue wire to neutral
- Yellow-green wire to ground terminal

The circuit breaker switches of the oven shall be placed so that end user can reach them when the oven is installed.

The power supply cord (the cord with plug) shall not contact the hot parts of the appliance.

If the power supply cord (the cord with plug) is damaged, this cord shall be replaced by the manufacturer or its service agent or an equally qualified person to prevent a hazardous situation.

INTRODUCING THE APPLIANCE

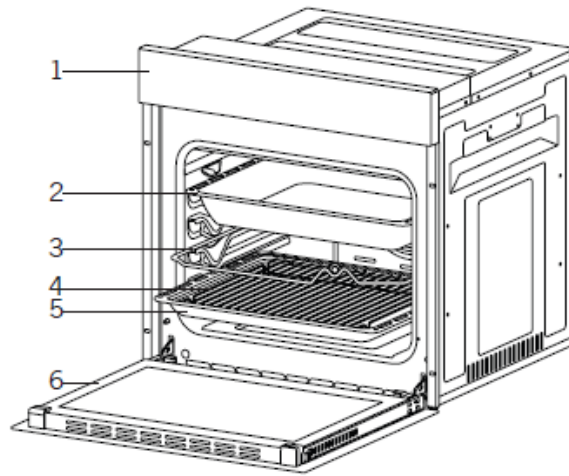





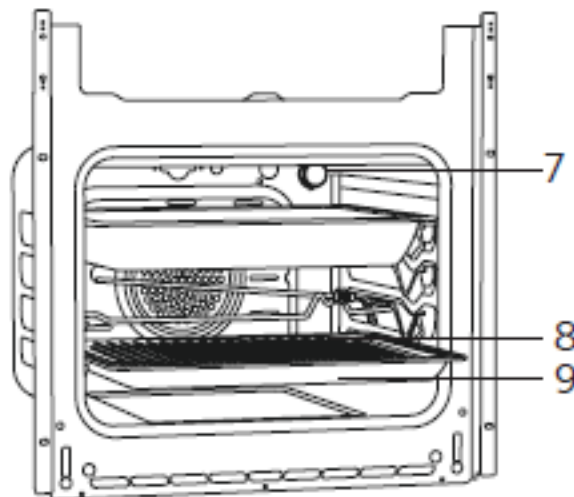

- 1. Control panel
- 2. Deep tray *
- 3. Chicken roast skewer *

- 4. Wire grill inside tray
- 5. Standard tray
- 6. Oven door



- 7. Light
- 8. Wire grill inside tray
- 9. Standard tray

ACCESSORIES (OPTIONAL)

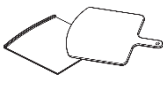
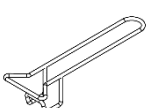
	<p>Deep tray * Used for pastry, big roasts, watery foods. It can also be used as oil collecting container if you roast directly on grill with cake, frozen foods and meat dishes.</p>
	<p>Tray / Glass tray * Used for pastry (cookie, biscuit etc.), frozen foods.</p>
	<p>Circular tray * Used for pastry frozen foods.</p>
	<p>Drying tray * It is used for foods that want to be dried.</p>
	<p>Wire grill Used for roasting or placing foods to be baked, roasted and frozen into desired rack.</p>
	<p>Telescopic rail * Trays and wire racks can be removed and installed easily thanks to telescopic rails.</p>
	<p>In tray wire grill * Foods to stick while cooking such as steak are placed on in tray grill. Thus, contact of food with tray and sticking are prevented.</p>
	<p>Pizza stone and peel * They are used for baking pastries such as pizza, bread, pancake and removing baked food from the oven.</p>
	<p>Tray handle * It is used to hold hot trays.</p>

*All accessories are not included on all models

TECHNICAL SPECIFICATIONS

MGA1-8..... :

Lamp power	15-25 W			
Thermostat	40-240 / Max °C			
Bottom heater	1200 W			
Top heater	1200 W			
Turbo heater	1800 W			
Grill heater	Small grill	1200 W	Large grill	2400 W
Supply voltage	220-240 V 50/60 Hz.			

MGA1-6..... :

Lamp power	15-25 W			
Thermostat	40-240 / Max °C			
Bottom heater	1200 W			
Top heater	1000 W			
Turbo heater	1800 W			
Grill heater	Small grill	1000 W	Large grill	2000 W
Supply voltage	220-240 V 50/60 Hz.			

WARNING: In order to increase the product quality, the technical specifications may be changed without prior notice.

WARNING: The values provided with the appliance, or its accompanying documents are laboratory readings in accordance with the respective standards. These values may differ depending on the usage of the appliance and ambient conditions.

WARNING: Figures in this manual are schematic and may not exactly match your product.

INSTALLATION OF APPLIANCE

Check if the electrical installation is proper to bring the appliance in operating condition. If not, call an electrician and plumber to arrange the utilities as necessary. Manufacturer shall not be held responsible for damages caused by operations performed by unauthorized persons.

WARNING: It is customer's responsibility to prepare the location the product shall be placed on and also to have the electrical installation prepared.

WARNING: The rules in local standards about electrical installations shall be followed during product installation.

WARNING: Check for any damage on the appliance before installing it. Do not have the appliance installed if it is damaged. Damaged products cause a risk for your safety.

Important Warnings for Installation:

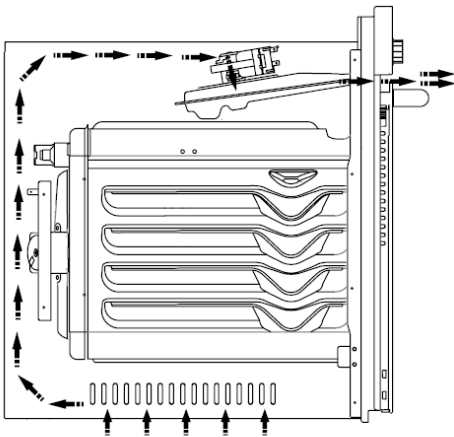

Figure 1

Cooling fan shall take extra steam out and prevent outer surfaces of appliance from overheating during operation of oven. This is a necessary condition for better appliance operation and better cooking.

Cooling fan shall continue operation after cooking is finished. Fan shall automatically stop after cooling is completed.

A clearance must be left behind the enclosure where you'll place the appliance for efficient and good operation.

This clearance shouldn't be ignored as it's required for ventilation system of the appliance to operate. This clearance shouldn't be ignored as it's required for ventilation system of the appliance to operate.

Right Place for Installation

The appliance is designed so that it shall fit commercially available counters. A safe clearance shall be left between the product and kitchen walls or furniture. Refer to the drawings on the installation section. for suitable clearances. (Dimensions are given in mm)

- Surfaces, synthetic laminates, and adhesives used shall be resistant to heat. (Minimum 100 °C)
- Kitchen cabinets shall be level with the appliance and fixed.
- A rack shall be placed between the oven and the shelf if there is a shelf under the oven.

WARNING: Do not install the appliance beside refrigerators or coolers. Heat radiated by the appliance increases the energy consumption of cooling devices.

WARNING: Do not use the door and/or handle to carry or move the appliance.

Installation and Assembly of The Oven

Operating space of the appliance shall be determined before starting the installation.

Appliance shall not be installed on areas with high flow of air.

Handle the appliance with two persons at least. Do not drag the appliance to prevent damage to the ground.

Remove all transportation materials inside and outside of the packaging. Remove all materials and documents inside the product.

Installation Under Counter

Cabinet shall conform with dimensions specified in fig. 2.

A clearance with the dimensions specified in the figure shall be ensured at the rear compartment of the cabinet to provide the required ventilation.

After installation, the clearance that shall be left between the bottom of the counter and the top of the appliance is indicated by "A" in fig. 5. This is for ventilation, and it shall not be closed.

Installation In a High Cabinet

The cabinet shall comply with the dimensions given in fig. 4.

In the rear part of the cabin, and at the top and bottom, clearances with the dimensions specified in the figure shall be ensured to provide the required ventilation.

Installation Conditions

The dimensions of the appliance are given in figure 3.

The furniture surfaces to be installed and the installation materials to be used shall resist a temperature of at least 100 °C.

To prevent the appliance from turning over, the cabinet to be installed shall be fixed and the cabinet floor shall be level.

The floor of the cabinet shall be strong enough to withstand a load of at least 60 kg.

Placing and Securing of The Oven

Place the oven to the cabinet with two or more persons.

Make sure that the frame of the oven and the front of the furniture are properly aligned.

The supply cord shall not be left under the oven or be stuck or bent between the oven and the furniture.

Secure the oven to the furniture using the screws supplied with the appliance. Screws shall be installed by putting them through the plastics attached on the frame of the appliance as shown in figure 5. The screws shall not be tightened too much. Otherwise, the screw holes may wear out.

Check that the oven does not move after installation. If the oven has not been installed in accordance with the installation instructions, there is a risk of overturning during operation.

Electrical Connection

The place where the product shall be installed shall have proper electrical installation.

The mains voltage shall comply with the rating given on the product type plate.

Connection of appliance shall be made in accordance with local and national electrical regulations.

Disconnect the mains power before starting to install the product. Do not connect the product to the mains until the installation is finished.

Assembly



Figure 2

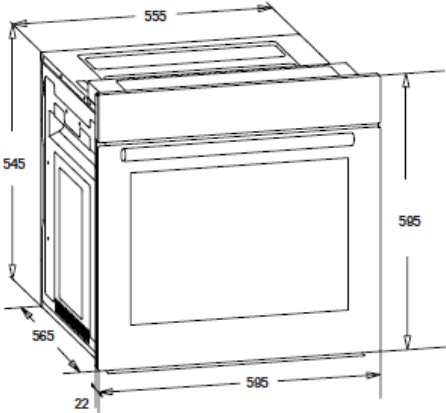
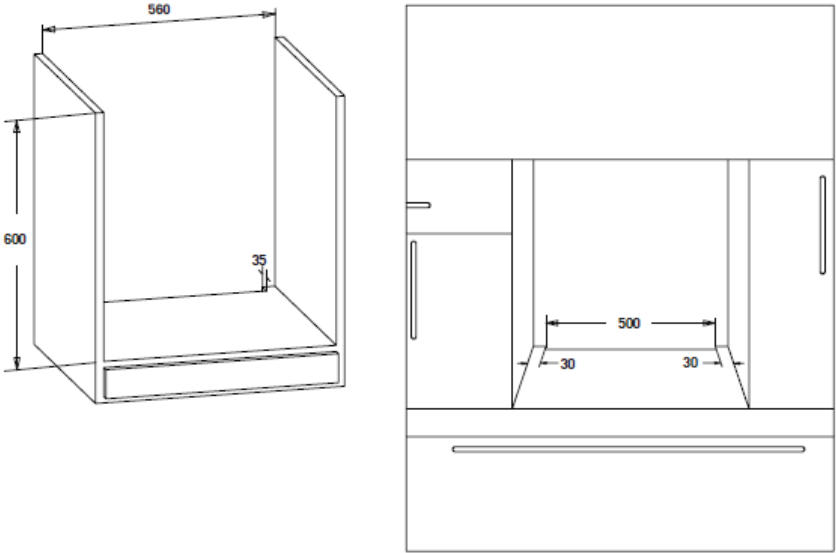

Figure 3

USER MANUAL

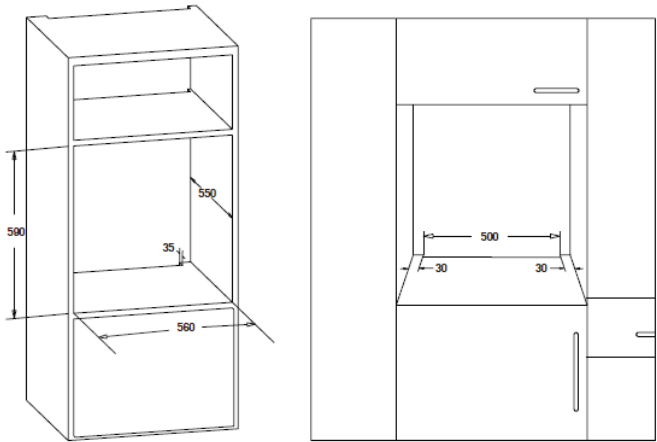
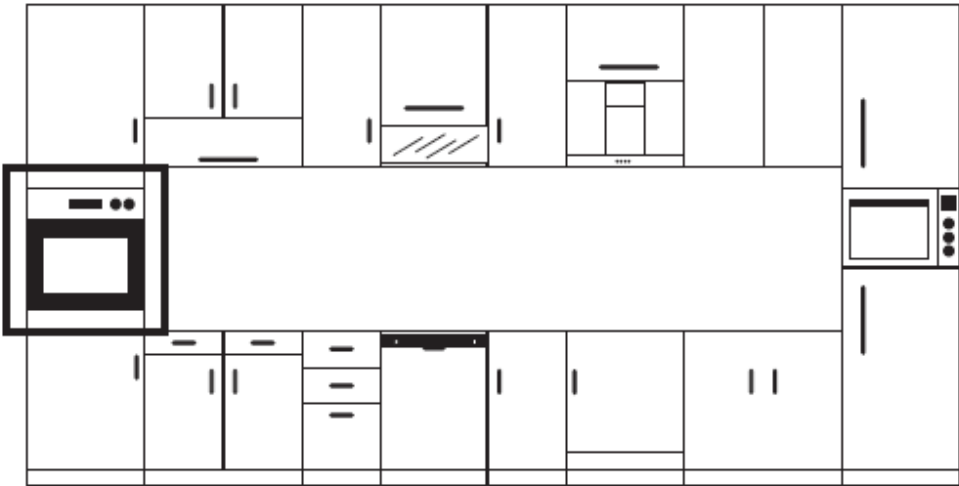

Figure 4

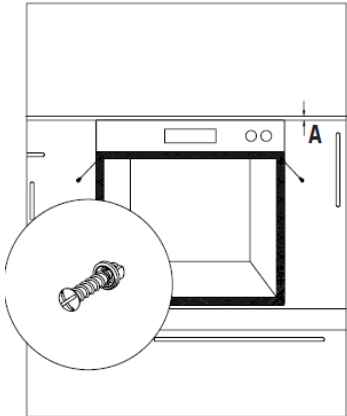
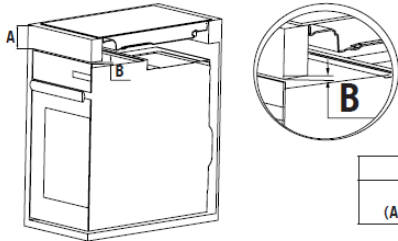

Figure 5



A	Min. 80 mm
B (Air outlet)	5 mm

At the front of the kitchen counter, a space at least 5 mm high from the bottom of the counter should be left.

OPERATION OF THE OVEN

Initial Operation of The Oven

After you have made the necessary connections of your oven according to the instructions, you shall need to do the following in the initial operation:

1. Take out any labels or accessories that are affixed inside the oven. If there is a protective foil on the front of the appliance, remove it.
2. Wipe the inside of the oven with a wet cloth to remove the dust and the remains of packaging. Inside of the oven shall be empty. Plug the appliance.
3. Set the thermostat button to the highest temperature (Max. 240 ° C) and operate the oven for 30 minutes with its door closed. At this time, little amount of smoke and smell may occur; this is normal.
4. After the oven has cooled down, wipe the inside of the oven with warm water with mild detergent and dry with a clean cloth. You can now use your oven.

Normal Operation of The Oven

1. To start cooking; set the thermostat button, program type and temperature level according to the meal that you want to cook.
2. When the cooking time has expired according to the entered information; the timer turns off the heaters and gives an audible signal.
3. Once the cooking process is complete, the cooling system of the appliance shall continue to operate. Do not cut off the power of the appliance, which is necessary for the appliance to cool. After cooling is complete, the system shall be automatically turned off.

Operation Of the Control Unit

This is an electronically controlled oven that allows your food to be ready for service at your desired cooking settings. What you need to do for it is to program how to cook the food you want to cook, the cooking time, the cooking temperature, and the time you want it to be ready. You may also use special functions. It can also be used as a minute programmable alarm clock independently of the cooking functions of your oven.

Key Features

- Programmable cooking functions and timer.
- Special cooking functions.
- Creating and recalling cooking favorites.
- Real-time clock unaffected by short-term energy interruptions.
- Cooking summary and monitoring screens.
- Brightness and tone settings.
- Timer for reminder.
- Easy-to-use touch keys and rotary knob that may be pressed.

General View

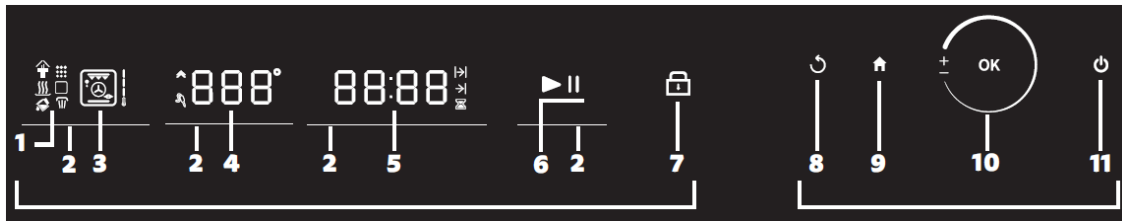

Status Indicators

1. Special functions
2. Active setting indicator
3. Manual mode indicator
4. Temperature indicator
5. Time display
6. Cooking status indicators

User Entries

7. Child lock indicator
8. Back button
9. Menu button
10. Rotary knob that may be pressed
11. On / off button

Symbols on the Display

Appliance features a LED display.

Special Functions

Function symbols of the oven are defined in the following table.

	Keep Warm
	Steam Cleaning
	Manual cooking

Temperature



Temperature symbols of the oven are defined in the following table.

	Quick heating (pre-heating)		
	Heat bars (oven interior temperature display)		Temperature display (°C)

USER MANUAL





Timing

Timing symbols of the oven are defined in the following table.

	Normal cooking		Delayed cooking
	Reminder timer		



Cooking

Cooking symbols of the oven are defined in the following table.

	Lower resistance		Upper resistance
	Grill resistance		Turbo resistance
	Turbo fan		







Status

Status display symbols of the oven are defined in the following table.

	Start		Stop		Child lock
---	-------	---	------	---	------------

Setup

Setting symbols of the oven are defined in the following table.

	Child lock setting		Clock setting
	Reminder timer setting		Tone setting
	Preheat setting		Setting brightness
	Call favourite		

Set-up

When the Oven Is Turned on for the First Time

Oven is deactivated when it is turned on for the first time. Clock that is not updated flashes on the screen. You shall set the clock first to operate the oven. Just follow the few steps below to perform the clock setting.















- The hours are set by turning the rotary knob while the clock flashes as “12:00” on the main screen.
- Confirm the hours setting by pressing once on the rotary knob.
- Then, the minutes are set, and the minutes setting is confirmed by pressing the rotary button once again.
- After these settings, you may start the oven using the on/off button.

Remark: If you want to change the time setting on the later operations of the oven, refer to the time setting section from the settings menu.

Cooking Menu

There are specific temperature and cooking times that may be used for each cooking function. Suggested cooking temperatures are based on conventional cooking habits and they may be changed according to personal preferences.

Cooking Function Displays and Their Features

	Lower and upper resistances work together. Recommended temperature is 200 °C. Allows cooking from 45 °C to 240 °C. Up to 6 hours of cooking is possible.
	Lower resistance, upper resistance and fan work together. Recommended temperature is 180°C. Allows cooking from 45 °C to 240 °C. Up to 6 hours of cooking is possible.
	Turbo and fan work together. Recommended temperature is 175 °C. Allows cooking from 45 °C to 240°C. Up to 8 hours of cooking is possible.
	Lower- upper resistances, turbo and fan work together. Recommended temperature is 180 °C. Allows cooking from 60 °C to 240 °C. Up to 5 hours of cooking is possible.
	Grill is operated. Recommended temperature is 180°C. Allows cooking from 120 °C to 230 °C. Up to 1 hours of cooking is possible.
	Grill and upper resistance work together. Recommended temperature is 200 °C. Allows cooking from 120 °C to 230 °C. Up to 1 hours of cooking is possible.
	Grill and fan work together. Recommended temperature is 175°C. Allows cooking from 120 °C to 230°C. Up to 1 hours of cooking is possible.
	Grill, fan and upper resistance work together. Recommended temperature is 185 °C. Allows cooking from 120 °C to 230 °C. Up to 1 hours of cooking is possible.
	Grill, fan and turbo work together. Recommended temperature is 220 °C. Allows cooking from 120 °C to 230 °C. Up to 4 hours of cooking is possible.
	Upper resistance is operated. Recommended temperature is 220 °C. Allows cooking from 60 °C to 150°C. Up to 2 hours of cooking is possible.
	Lower resistance is operated. Recommended temperature is 200 °C. Allows cooking from 60 °C to 230 °C. Up to 8 hours of cooking is possible.
	Operates in Thawing (Defrost) mode. Up to 8 hours of operation is possible.
	Lower resistance, fan and turbo work together. Recommended temperature is 150 °C. Allows cooking from 45 °C to 230 °C. Up to 4 hours of cooking is possible.
	Upper resistance, fan and turbo work together. Recommended temperature is 150 °C. Allows cooking from 45 °C to 230 °C. Up to 4 hours of cooking is possible.

Manual Cooking

Thanks to its control system and the pre-set temperature values, your oven is very easy to operate. The steps you need to follow to start cooking are explained below.



Figure 6



Figure 6.1

1. The oven is turned on by pressing the on/off button. Then, when the rotary knob is pressed once, the cooking menu opens.

2. In the cooking menu, the active setting indicator displays the cooking functions (see Fig. 6) first, and you may turn the rotary knob to switch between the functions and to select the desired cooking function.

3. After pressing the rotary knob, the active setting indicator switches to the temperature display. (see Fig. 7) Rotate the rotary knob to set the desired temperature value within the specified limits. The desired temperature value is confirmed by pressing the rotary knob. (see Fig. 8)

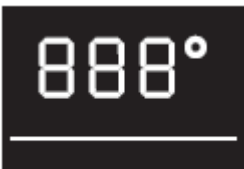

Figure 7



Figure 8

WARNING: While switching between functions, the temperature values displayed on the temperature display are the recommended temperature values. Temperature may be changed between maximum and minimum temperatures specified at 5°C intervals.

4. Cooking time is set when the active setting indicator is on the time display. Once the oven has been set to the desired cooking function and temperature, the desired cooking time is set by turning the rotary knob and confirmed by pressing the button once.

5. The desired cooking function, temperature and time are set. (see Fig. 9)



Figure 9

Normal Cooking

It is used when cooking is required to start immediately. The desired time is set. (see Fig. 10)



Figure 10

When the rotary knob is pressed and the active setting indicator is in the same place, the time setting for the cooking end time is displayed in the time display. (see Fig. 11)



Figure 11

Remark: The time of day is taken as **12.00**.

By pressing the rotary switch a second time, the cooking time is set and the active setting indicator switches to the start ► / stop || menu. (see Fig. 12)



Figure 12

WARNING: By pressing the active setting indicator again, you may exit from the cooking menu.

Delayed Cooking

This method is used when the food is desired to be cooked and ready at a certain time in the future. The following example can be used for delayed cooking.

Example:

Let's say that the time of day is **12:00**. (see Fig. 13)

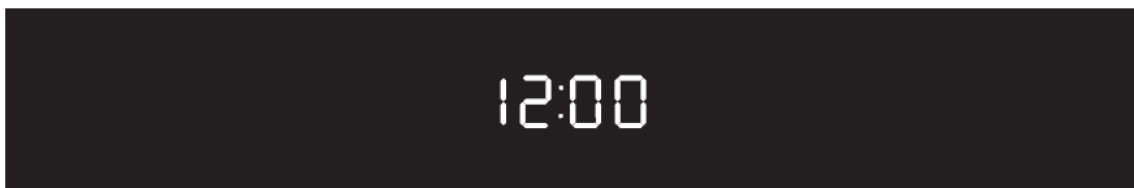

Figure 13

USER MANUAL

The cooking time is set to 10 minutes by turning the rotary knob (see Fig. 14) and confirmed by pressing the rotary knob once. (See Fig. 15)



Figure 14



Figure 15

Let's cook by delaying the cooking time we have set as **12:10** for **20 minutes**:

By turning the rotary knob, delaying time is set and the time at which the cooking shall end is specified. (see Fig. 16)

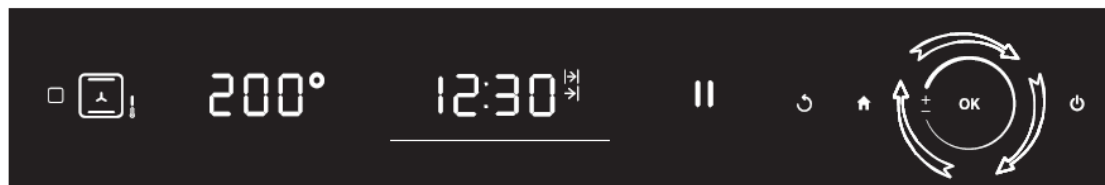

Figure 16

Remark: Minutes are increased at 5-minute intervals whenever you turn the rotary knob.

Confirm the ending time for cooking by pressing on the rotary knob once. (see Fig. 17)



Figura 17

The screen displayed is as follows after confirming the delayed cooking. (see Fig. 18)



Figure 18

USER MANUAL

Cooking starts when 10 minutes, which is the cooking time, are left on the clock display, and the screen is displayed as follows. (see Fig. 19)



Figure 19

As we have seen in the example above, if the oven we have set **10 minutes** of cooking at **12:00** was set for the normal cooking time, our cooking would have ended at **12:10**. But, we have **delayed that for 20 minutes**, and ensured that the cooking has ended at **12:30**.



Remark: Just press the rotary knob for 1 second to stop cooking.

Remark: Just press the back button for 2 seconds to cancel cooking completely.

Remark: To change the cooking settings; press the back button after stopping the cooking and the active setting display switches to the time display, the temperature display and the cooking functions, respectively. The desired settings may be changed again on the cooking menu.

Special Functions

There are 3 special functions in this menu. Special function menus may be accessed by pressing the menu key twice on the touch screen while the oven is turned on.

	<p>Keep warm function</p> <ul style="list-style-type: none">• This function is developed to keep the oven warm.• Recommended temperature is 70 °C. The temperature may be set from 45 °C to 100 °C.• The maximum operating time is specified as 6 hours.
	<p>Steam cleaning function</p> <ul style="list-style-type: none">• Operates at 70 °C for 30 minutes.

Keep Warm Mode

This function is used to keep the oven warm. Press twice on the menu on the touch screen to select the special functions menu. (see Fig. 22)

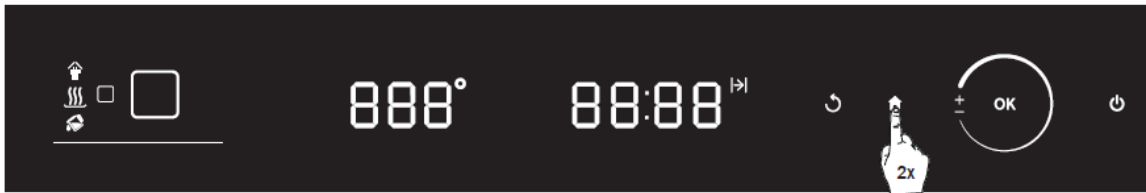



Figure 22

Select keep warm mode by rotating the rotary knob on the special functions menu. (see Fig. 23)



Figure 23

Select keep warm mode by pressing the rotary knob once when the keep warm icon () appears on the touch screen. (see Fig. 24) It may be set from 45 °C to 100 °C. The recommended temperature is 70 °C. Maximum operating period is 6 hours.

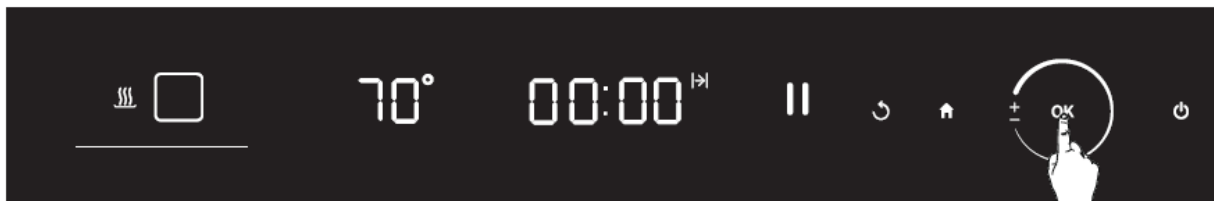

Figure 24

Steam Cleaning Mode

This allows cleaning of the dirt that is softened by the steam occurred inside the oven.

A few steps that shall be realized before starting the steam cleaning are explained below:

1. Remove all accessories from the oven.
2. Put half a litre of water in the tray and place the tray to the bottom of the cooker.
3. Operate the steam cleaning function.
4. After operating the oven for 30 minutes, open the door and wipe the inner surfaces of oven with a damp cloth.
5. Clean the oven using dish washing detergent, warm water, and a soft cloth for dirt that does not come out easily and wipe the area you have cleaned with a dry cloth.

To set the steam cleaning function.

Press twice on the menu on the touch screen to select the special functions menu. (see Fig. 25)



Figure 25

Select steam cleaning mode by rotating the rotary knob on the special functions menu. (see Fig. 26)

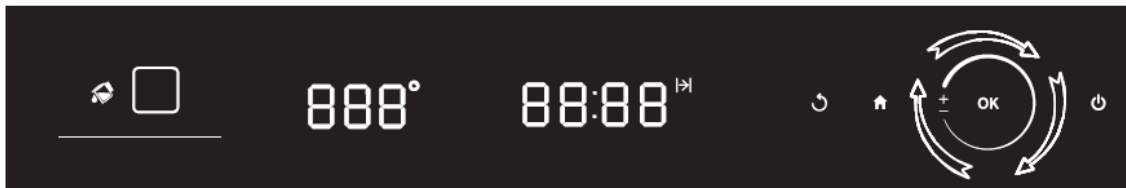

Figure 26

Select steam cleaning mode by pressing the rotary knob once when the steam cleaning icon () appears on the touch screen. (See Fig. 27) Lower resistance is operated. The recommended temperature is 70 °C.

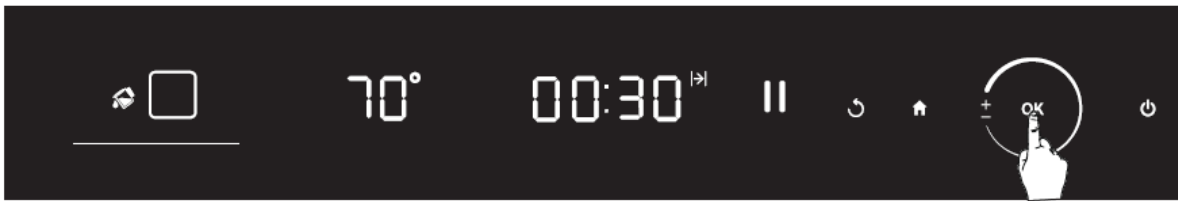

Figure 27

WARNING: Steam cleaning and keep warm modes cannot be selected when the oven is over 100 °C.

Settings

Turn the oven on by pressing the on/off button. You may enter the settings by pressing the menu button once. You may switch between settings by rotating the rotary knob.

Child Lock Mode Setting **chd**

The child lock function may be used to prevent situations such as operating the oven or stopping the running program accidentally by touching the keys.

In order to activate the child's lock;

In the settings menu, press the rotary knob while the active setting indicator is on the child lock ("**chd**") tab. (see Fig. 28)



Figure 28

Select “ON” from the **ON /OFF** positions by rotating the rotary knob. (See Fig. 29)



Figure 29

Confirm the selected “ON” position by pressing on the rotary knob once, and thus the child lock is activated. (see Fig. 30)



Figure 30

Time of the day and child lock symbol is displayed on the screen when the rotary knob is pressed again. (see Fig. 31)

In order to cancel the child's lock;

Press the menu key for 3 seconds, and the symbol disappears from the screen. (see Fig. 32)



Figure 32

WARNING: Oven may be turned off while the child lock is active, but it is not possible to turn the oven on without cancelling the child lock.

Reminder Timer Setting

Alarms with the desired period may be set on the reminder timer setting. At the end of the period set, oven clock alarm shall sound and indicate that the set time has expired.

To set the alarm;

On the settings menu, rotate the rotary knob to the alarm tab (“**Alr**”). (see Fig. 33)



Figure 33

Press the rotary knob once to switch to the hours mode. (see Fig. 34)



Figure 34

Set the desired minutes and hours by rotating the rotary knob. (see Fig. 35)



Figure 35

Then confirm the set time by pressing the rotary knob. Time of the day and hourglass symbol is displayed on the



Figure 36

screen after the confirmation. (see Fig. 36)

WARNING: Alarm may be set up to **23 hours and 55 minutes** at most. **When the set reminder time has expired;**

- Alarm sounds.
- Hourglass symbol flashes during the alarm.
- Reminder alarm may be turned off by pressing any key.
- Alarm ends automatically after 7 minutes and hourglass symbol disappears when no key is pressed.
- Time of the day is displayed on the touch screen.

Brightness Setting **brt**

On the settings menu, rotate the rotary knob to the brightness setting tab (“brt”). (see Fig. 37)



Figure 37

Enter the brightness setting by pressing the rotary knob. (see Fig. 38)



Figure 38

Brightness setting is brought to the desired setting from 1 to 8 by rotating the rotary knob. (see Fig. 39)



Figure 39

After setting the desired brightness level, it is confirmed by pressing the rotary knob. (see Fig. 40)



Figure 40

Pre-heat (Boost) Mode Setting

This is used to bring the interior temperature of the oven to the desired level quickly.

On the settings menu, rotate the rotary knob to the pre-heat (Boost) ("brt") tab. (see Fig. 41)

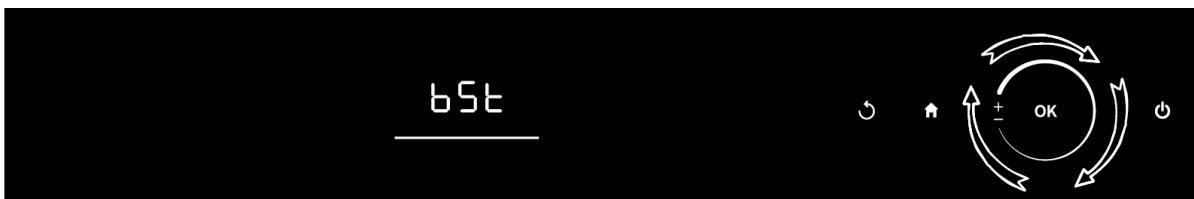

Figure 41

Enter the pre-heat ("bst") setting by pressing the rotary knob. (see Fig. 42)



Figure 42

On the pre-heat ("bst") setting, select "ON" from the ON /OFF positions by rotating the rotary knob. Thus, the pre-heat (Boost) is turned on. (see Fig. 43)



Figure 43

Beside the time of the day, “” pre-heat (**Boost**) icon is displayed on the upper left side of the temperature indicator on the touch screen. (see Fig. 44)

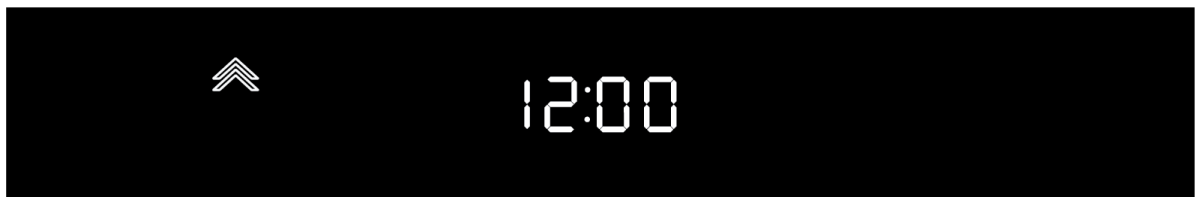



Figure 44

Remark: Oven sounds a short warning tone when pre-heating is completed. Pre-heat “” (Boost) symbol disappears.

Favourite Mode Setting

Cooking settings may be saved when you want to use these setting again. Your oven features a memory for 10 favourite settings. You may your dishes to favourites in two ways:

1. Adding to favourites during cooking;

After setting the cooking function, the cooking temperature, and the desired cooking time, stop cooking by pressing the rotary knob for 1 second while the dish is being cooked in the oven. (see Fig. 45)

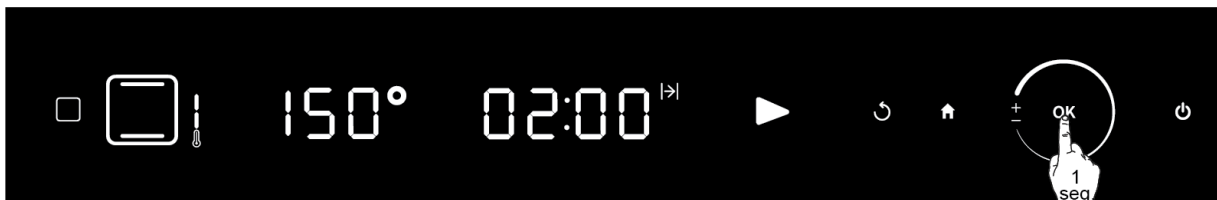

Figure 45

Press menu button once. Favourites menu is displayed on the screen. (see Fig. 46)



Figure 46

You may select the favourite number you want to add by rotating the rotary knob. (see Fig. 47)



Figure 47

Then, you may save the changes made up to that time by pressing the rotary knob, and add your cooking to the favourites. (see Fig. 48)



Figure 48

2. Adding to favorites after cooking;

Favourite ("fau") menu is displayed on the touch screen if you press the menu button once when the cooking is completed. (see Fig. 49)



Figure 49

Select the favourite number you want to add by rotating the rotary knob. (see Fig. 50)

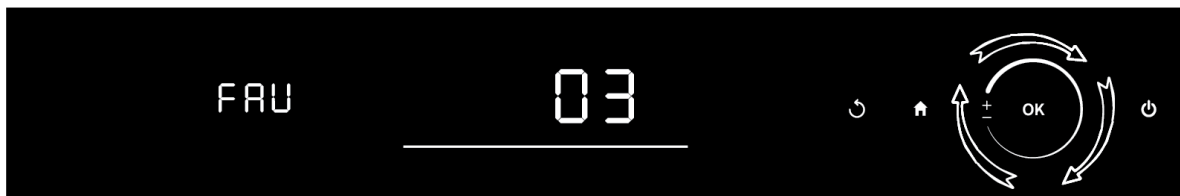

Figure 50

Then, you may add your cooking to the favourites by pressing the rotary knob once. (see Fig. 51)



Figure 51

Activating favourite cookings;

Favourite (“fau”) menu is displayed on the touch screen if you press the menu button once while the oven is on. (see Fig. 52)



Figure 52

Select the desired favourite number by rotating the rotary knob (see Fig. 53)

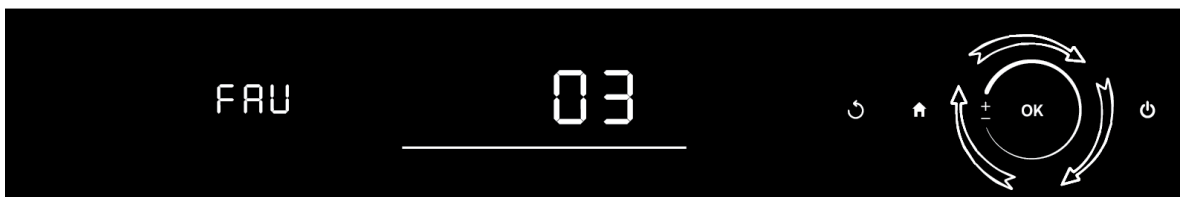

Figure 53

Then, you may activate saved cooking settings by pressing the rotary knob. Active setting indicator is on the start/stop tab, and you may start cooking whenever you desire. (see Fig. 54)

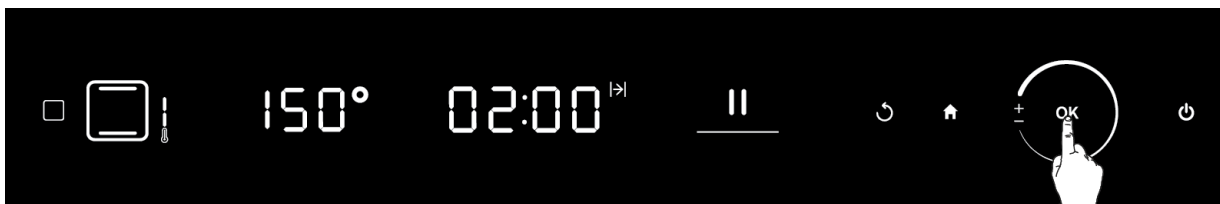

Figure 54

WARNING: Cooking position, temperature levels and cooking times provided are examples only.

WARNING: Settings remain in the memory even if the power is interrupted.

WARNING: Favourite settings may not be used for cooking with meat probe.

Cooking settings may be saved up to 3 different steps for favourite cooking.

1. You may add a cooking that is performed by operating the lower and upper resistance for 25 minutes at 200 °C. (see Fig. 55)

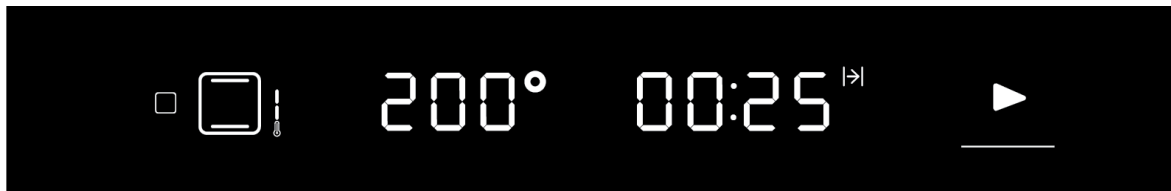

Figure 55

2. You may add a cooking that is performed by operating the grill and fan for 20 minutes at 175 °C. (see Fig. 56)



Figure 56

3. You may add a cooking that is performed by operating the turbo and fan for 30 minutes at 170 °C. (see Fig. 57)

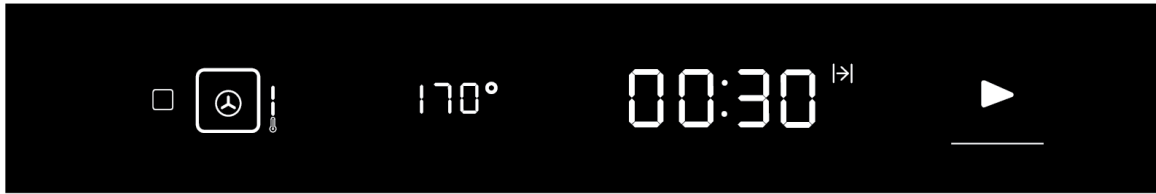

Figure 57

Clock Setting Hr

Press the on/off button once, oven turns on and the oven lamp is illuminated. (see Fig. 58)



Figure 58

On the settings menu, rotate the rotary knob to the Clock ("Hr") menu on the touch screen. (see Fig. 59)

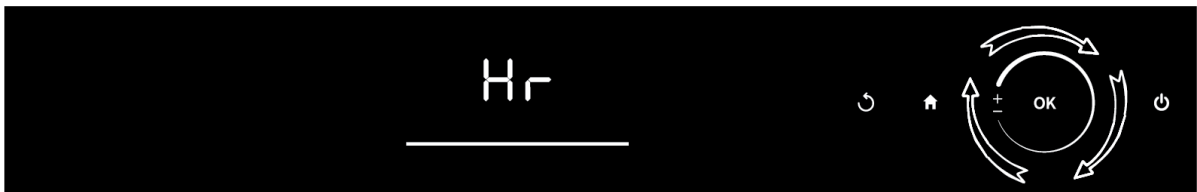

Figure 59

Hours tab flashes when the rotary knob is pressed once. (see Fig. 60)

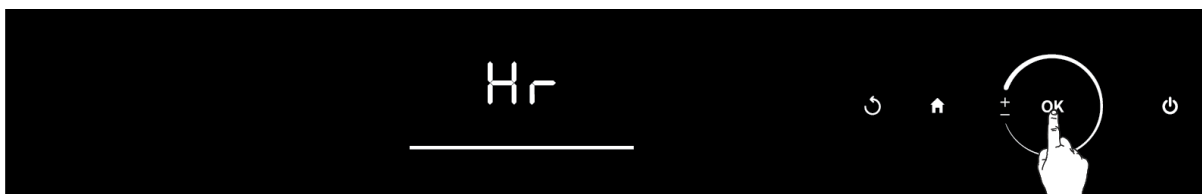

Figure 60

Select the desired hours value by rotating the rotary knob. (see Fig. 61)



Figure 61

Minutes tab flashes when the rotary knob is pressed for the second time. (see Fig. 62)



Figure 62

Select the desired minutes value by rotating the rotary knob. (see Fig. 63)



Figure 63

Confirm the time you have set by pressing on the rotary knob for the third time. (see Fig. 64)

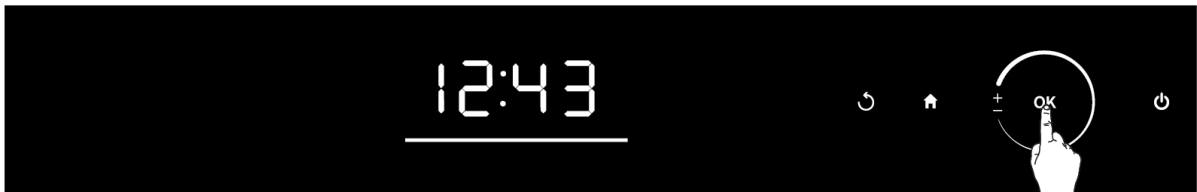

Figure 64

Remark: The time of day is taken as 12:00 as an example.

WARNING: Display returns to main screen after the clock setting is completed.

WARNING: Setting mode shall be cancelled automatically after about 30 seconds if no key is pressed.

WARNING: Clock setting may be performed when there is no active cooking program only.

Tone Setting **ton**

Your oven features three different tone settings and a mute option. “**ton 0**” mutes the key tones of your oven.

To set the tone of your oven;

On the settings menu, rotate the rotary knob to the tone setting (“ton”) tab. (see Fig. 65)



Figure 65

Press the rotary knob once after entering the tone setting (“**ton**”) tab. (see Fig. 66)



Figure 66

Then, select the desired tone by rotating the rotary knob. (see Fig. 67)



Figure 67

Press the rotary knob once to confirm after setting the desired tone. (see Fig. 68)

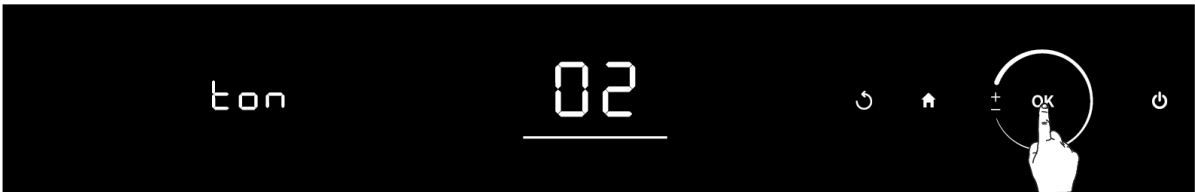





Figure 68

WARNING: “**ton 0**” mutes the key tones of your oven only. It does not affect the warning sounds.

USER MANUAL

Temperature Bars

This is the internal temperature and warning sign. Divides the temperature you have set equally and it is incremented by 1 bar for each 1/4 portion

Bar levels	Sample cooking temperature	Bar Increment Levels as per the temperature
	If the cooking is set to 180 °C	First bar is activated at 45 °C.
		Second bar is activated at 90 °C.
		Third bar is activated at 135 °C.
		Fourth bar is activated at 180 °C.

WARNING: Your oven takes the temperature scale as 240 °C if there is no active cooking. Electronic Card Error Codes and Recommended Solutions

Electronic card error codes, their descriptions and recommended solutions are given in the table below.

Error Codes	Description	What To Do
F1	Electronics are extremely heated and resistances are stopped.	Wait for the oven to cool down.
F2	Supply voltage error.	Check whether the supply voltage is normal.
F3	Temperature sensor is open circuit or short circuit.	Contact authorized service.
F4	Temperature sensor exceeds 350 °C.	Contact authorized service.
F5	Maximum operating period is exceeded in manual mode.	Restart cooking.
F6	Real time clock error.	Contact authorized service.
F8	Self-check, general electronics error.	Contact authorized service.
F9	Connection error.	Contact authorized service.

OPERATION OF THE GRILL

When you place the grill on the top rack, the food on the grill shall not touch the grill.

You can preheat for 5 minutes while grilling. If necessary, you may turn the food upside down.

Food shall be in the center of the grill to provide maximum air flow through the oven.

To turn on the grill;

1. Place the function button over the grill symbol.
2. Then, set it to the desired grill temperature.

To turn the grill off;

Set the function button to the off position.

WARNING: Keep the oven door closed while grilling.

COOKING RECOMMENDATIONS

Below you may find the information about the food we have tested in our laboratories to determine their cooking times. Cooking times may vary as per mains voltage, quality, amount of the ingredients to be cooked, and the temperature. Meals you cook using these values may not appeal to your tastes. You may discover different values by making experiments to achieve different flavours and results that appeal to your taste.

WARNING: Oven shall be pre-heated for 7 to 10 minutes before placing the food into the oven.

COOKING TABLE

MGA1-8..... :

Food	Cooking function	Cooking temperature (°C)	Cooking rack	Cooking time (min.)
Muffin	Static / Static+fan	170-180	2-3	35-45
Pie	Static / Static+fan	180-200	2-3	35-45
Buns	Static	180-190	2	35-45
Cookie	Static / Turbo+fan	170-180	2-3	20-25
Apple pie	Static / Turbo+fan	180-190	2-3	50-70
Sponge cake	Static / Turbo+fan	200/150 *	2-3	20-25
Pizza	Static / Turbo+lower	180-200	3	20-30
Lasagne	Static	180-200	2-3	25-30
Macaroon	Static / Lower-upper+fan	100	2-3	50-70
Grilled Chicken **	Grill / Lower-upper+fan	200-220	2-3	25-35
Grilled Fish **	Grill	190-200-220	3-4	25-35
Grilled Steak **	Grill	230	5	30-35
Grilled meatballs **	Grill	230	5	25-30

* Do not preheat. First half of cooking time is recommended to be at 200 °C de while the other half at 150 °C.

** Food must be turned after half of the cooking time.

MGA1-6..... :

Food	Cooking function	Cooking temperature (°C)	Cooking rack	Cooking time (min.)
Muffin	Static / Static+fan	170-180	2-3	35-45
Pie	Static / Static+fan	180-200	2	35-45
Buns	Static	180-190	2	35-45
Cookie	Static	170-180	1	20-25
Apple pie	Static / Static+fan	180-190	1	50-70
Sponge cake	Static	200/150 *	2	20-25
Pizza	Static fan	180-200	3	20-30
Lasagne	Static	180-200	2-3	25-30
Macaroon	Grill+fan	100	2	50
Grilled Chicken **	Grill+fan	200-220	3	25-35
Grilled Fish **	Grill+fan	190-200-220	3	25-35
Grilled Steak **	Grill+fan	Max	4	15-20
Grilled meatballs **	Grill+fan	Max	4	20-25

* Do not preheat. First half of cooking time is recommended to be at 200 °C de while the other half at 150 °C.

** Food must be turned after half of the cooking time.

Drying

MAINTENANCE AND CLEANING

Periodical cleaning extends the appliance's life and reduces frequent problems.

WARNING: Unplug the appliance. Shock hazard.

WARNING: Wait until the appliance cools down before cleaning it. Hot surfaces may cause burns

1. Do not clean the interior parts, panel, trays and other parts of the appliance with sharp tools such as bristle brushes, steel wool or knives. Do not use abrasive and scratching materials or detergents.
2. After cleaning the internal parts of the appliance with a soapy cloth, rinse and dry them thoroughly with a soft cloth.
3. Clean glass surfaces with special glass cleaning materials.
4. Do not clean your appliance using steam cleaners.
5. Do not use flammable materials such as acids, thinner or gas to clean your appliance.
6. Do not wash any component of your appliance in a dishwasher.
7. Use potassium stearate (soft soap) for dirt and stains.
8. Clean the control panel with a wet cloth and then dry it with a dry cloth.
9. Product must be thoroughly cleaned after each use. This way, it will be possible to remove the food remains easily and to prevent these remains from burning when the appliance is used again.
10. Make sure to wipe the remaining liquids away completely after cleaning and immediately clean the dishes that are splashed around during cooking.
11. Some detergents or cleaning agents may damage the surface. Do not use abrasive detergents, cleaning powders, cleaning creams or sharp objects during cleaning.

CLEANING AND ASSEMBLY OF THE OVEN DOOR

To replace the oven door again; reverse the procedure for removing the door.

Cleaning Of The Oven Glass

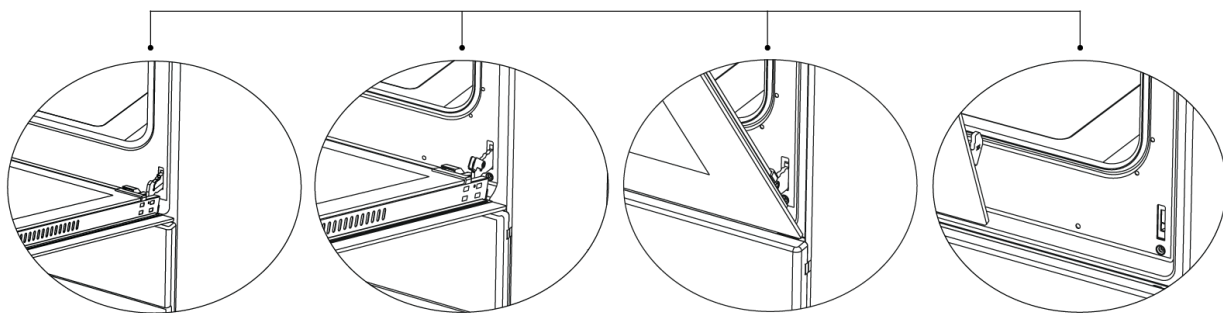
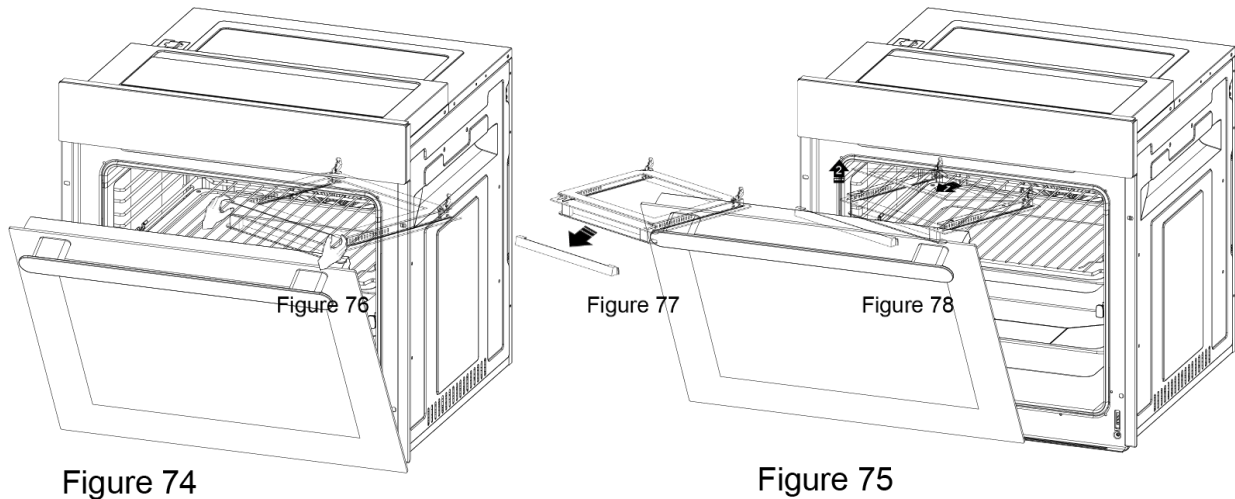

Figure 74.1

Open the door completely by pulling the oven door toward you. Then, as shown in figure 74.1, pull the hinge lock up with a screwdriver and perform the unlocking operation.

Figure 74.2

As shown in figure 74.2, bring the hinge lock to the maximum angle. Bring both hinges that connect the oven door to the oven to the same position.

Figure 75.1

Then, close the oven door you have opened so that it shall lean against the hinge lock as shown in figure 75.1.

Figure 75.2

To remove the oven door, hold the door with both hands when it is at a close level to the closed position, and pull it up as shown in figure 75.2.

Open the oven door. Pull out the plastic latches on the right and left side as shown in figure 76 and pull out the profile towards yourself as shown in figure 77. Glass is free after the profile is removed as shown in figure 78. Carefully pull the glass that has become free toward you. The outer glass is fixed to the oven door profile. You may easily clean the glasses after they have been separated. Once the cleaning and maintenance is complete, you may replace the glasses by performing the removal procedure in reverse. Make sure that the profile is seated properly.

WIRE RACK POSITIONS

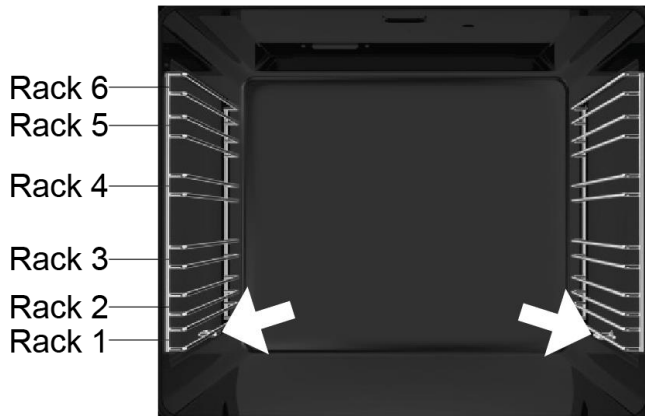

It is important to place the wire grill into the oven properly. Do not allow wire rack to touch rear wall of the oven. Rack positions are shown in the next figure. You may place a deep tray or a standard tray in the lower and upper wire racks.

Installing and removing wire racks

To remove wire racks, press the clips shown with arrows in the figure, first remove the lower, and then the upper side from installation location. To install wire racks; reverse the procedure for removing wire rack.

REPLACEMENT OF THE OVEN LAMP

WARNING: Disconnect power supply and wait for the oven to cool down to eliminate the risk of electrocution before replacing the oven lamp. Hot surfaces may cause burns.

Remove the glass protector by rotating it. Using plastic gloves may help you if you have difficulty in rotating it.

Then, remove the lamp by rotating it, and install the new lamp with the same specifications. Replace the glass protector, plug the appliance and complete the replacement procedure. You may now use your oven.

Type G9 Lamp



220-240 V, AC
15-25 W

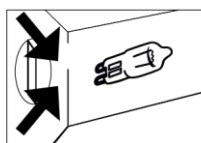

Figure 79

Type E14 Lamp



220-240 V, AC
15 W



Figure 80

WARNING: This product contains a light source of energy efficiency class G.

TROUBLESHOOTING

You may solve the problems you may encounter with your product by checking the following points before calling the technical service.

Check Points

In case you experience a problem about the oven, first check the table below and try out the suggestions.

USER MANUAL

Problem	Possible Cause	What to Do
Oven does not operate.	Power supply not available.	Check for power supply.
Oven does not operate.	Plug comes out from the wall socket.	Re-install the plug into wall socket.
Turns off during cooking.	Too long continuous operation.	Let the oven cool down after long cooking cycles.
	Cooling fan not operating.	Listen the sound from the cooling fan.
	Oven not installed in a location with good ventilation.	Make sure clearances specified in operating instructions are maintained.
	More than one plugs in a wall socket.	Use only one plug for each wall socket.
Outer surface of the oven gets very hot during operation.	Oven not installed in a location with good ventilation.	Make sure clearances specified in operating instructions are maintained.
Oven door is not opening properly.	Food residues jammed between the door and internal cavity.	Clean the oven well and try to re-open the door.
Internal light is dim or does not operate.	Foreign object covering the lamp during cooking.	Clean internal surface of the oven and check again.
	Lamp might be failed.	Replace with a lamp with same specifications.
Electric shock when touching the oven.	No proper grounding.	Make sure power supply is grounded properly.
	Ungrounded wall socket is used.	
Water dripping.	Water or steam may generate under certain conditions depending on the food being cooked. This is not a fault of the appliance.	Let the oven cool down and than wipe dry with a cloth.
Steam coming out from a crack on oven door.		
Water remaining inside the oven.		
The cooling fan continues to operate after cooking is finished.	The fan operates for a certain period for ventilation of internal cavity of the oven.	This is not a fault of the appliance; therefore you don't have to worry.
Oven does not heat.	Oven door is open.	Close the door and restart.
	Oven controls not correctly adjusted.	Read the section regarding operation of the oven and reset the oven.
	Fuse tripped or circuit breaker turned off.	Replace the fuse or reset the circuit breaker. If this is repeating frequently, call an electrician.

USER MANUAL

Smoke coming out during operation.	When operating the oven for the first time	Smoke comes out from the heaters. This is not a fault. After 2-3 cycles, there will be no more smoke.
	Food on heater.	Let the oven to cool down and clean food residues from the ground of the oven and surface of upper heater.
When operating the oven burnt or plastic odour coming out.	Plastic or other not heat resistant accessories are being used inside the oven.	At high temperatures, use suitable glassware accessories.
Oven does not cook well.	Oven door is opened frequently during cooking.	Do not open oven door frequently, if the food you are cooking does not require turning. If you open the door frequently internal temperature drops and therefore cooking result will be influenced.

HANDLING RULES

1. Do not use the door and/or handle to carry or move the appliance.
2. Carry out the movement and transportation in the original packaging.
3. Pay maximum attention to the appliance while loading/unloading and handling.
4. Make sure that the packaging is securely closed during handling and transportation.
5. Protect from external factors (such as humidity, water, etc.) that may damage the packaging.
6. Be careful not to damage the appliance due to bumps, crashes, drops, etc. while handling and transporting and not to break or deform it during operation.

RECOMMENDATIONS FOR ENERGY SAVING

Following details will help you use your product ecologically and economically.

1. Use dark coloured and enamel containers that conduct the heat better in the oven.
2. As you cook your food, if the recipe or the user manual indicates that pre-heating is required, pre-heat the oven.
3. Do not open the oven door frequently while cooking.
4. Try not to cook multiple dishes simultaneously in the oven. You may cook at the same time by placing two cookers on the wire rack.
5. Cook multiple dishes successively. The oven will not lose heat.
6. Turn off the oven a few minutes before the expiration time of cooking. In this case, do not open the oven door.
7. Defrost the frozen food before cooking.

Help and Assistance

If you require any technical guidance or find that your Built In Oven is not operating as intended, a simple solution can often be found in the Troubleshooting section of these instructions or online at www.creda.co.uk

If you still require further assistance, call one of our experts on 01759 487836. To help give us give you a fast and efficient service please have the following information ready:

You can find the following on the rating plate - a small information panel (usually a sticker or metal plate) on the rear of your appliance.

Model Ref.

Serial Number

Date of Purchase (this will be on your receipt)

Local call rates apply*

Lines open 9am-5:30pm Monday to Friday

*Calls to Creda enquiry lines may attract a charge and set up fee from residential lines depending on your call plan/tariff. Mobile and other providers costs may vary, see www.bt.com/pricing for details.

For Security and training purposes, telephone calls to and from customer service centres maybe recorded and monitored. Calls from Republic of Ireland will attract international call charges.

Creda

Call us now and activate your 3 years guarantee

Thank you for choosing Creda. Your new product is guaranteed against faults and breakdowns for 3 years. Don't forget to register it with us today so we can provide you with our best possible after-sales service and useful updates.

www.creda.co.uk

01759 487836

Your Creda Guarantee

This product is guaranteed for 3 years from the date of original purchase. Any defect that arises due to faulty materials or workmanship will be repaired free of charge (or if applicable the product will be replaced or the purchase price refunded) where possible during this period by the dealer from who you purchased the unit.

The guarantee is subject to the following provisions:

- The guarantee does not cover accidental damage, misuse, cabinet parts, knobs or consumable items.
- The product must be correctly installed and operated in accordance with the instructions contained in the manual.
- It must be used solely for domestic purposes. The guarantee will be rendered invalid if the product is re-sold or has been damaged by inexpert repair.
- Specifications are subject to change without notice.
- Creda disclaim any liability for loss or damage arising from the breakdown of the product.
- This guarantee is in addition to and does not diminish your statutory or legal rights.

Important Data Protection Information

To find out how we use your data please refer to the guarantee registration material or visit www.creda.co.uk

Declaration of conformance to product standards

This appliance conforms to all relevant standards applicable to domestic appliances sold in the UK.



Disposal

This appliance/fitting is marked according to the European directive 2012/19/EU on Waste Electrical and Electronic Equipment (WEEE).

By ensuring this product is disposed of correctly, you will help prevent potential negative consequences for the environment and human health, which could otherwise be caused by inappropriate waste handling of this product.

The symbol on the product, or on the documents accompanying the product, the **crossed out wheellie bin** symbol, indicates that this appliance/fitting may not be treated as household waste. Instead, it shall be handed over to the applicable collection point for the recycling of electrical and electronic equipment.

Disposal must be carried out in accordance with local environmental regulations for waste disposal.

For more detailed information about treatment, recovery, and recycling of this product, please contact your local authority, your household waste disposal service or the retailer where you purchased the product.